

Operation manual

LAUDA Universa ECO

Immersion thermostats, heating and cooling thermostats

ECO, U 8 E, U 12 E, U 16 E, U 6 TE, U 15 TE, U 20 TE, U 830 E, U 1225 E, U 1625 E

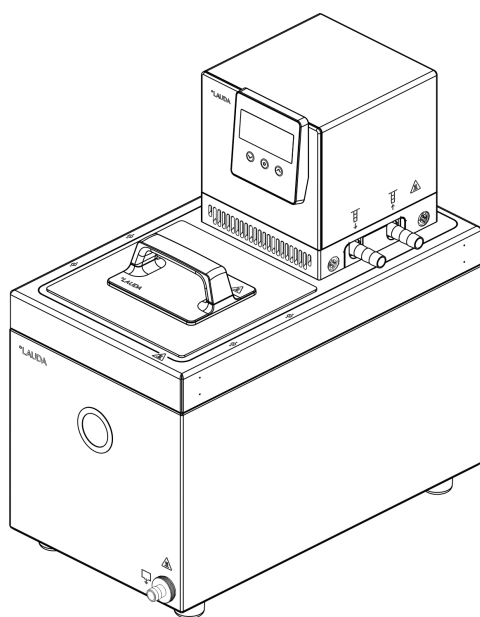

Manufacturer:

LAUDA DR. R. WOBSEER GMBH & CO. KG

Laudaplatz 1

97922 Lauda-Königshofen

Germany

Telephone: +49 (0)9343 503-0

E-mail: info@lauda.de

Internet: <https://www.lauda.de>

Translation of the original operation manual

Q4DT-E_13-022, 2, en_US © LAUDA 2025

replaces issue V1R45

04/16/2026

Table of contents

1	Safety.....	6
1.1	General Information.....	6
1.2	Intended use.....	6
1.3	Obligations of the operator.....	7
1.4	Prohibition of modifications to the device.....	8
1.5	Observing additional operating instructions.....	8
1.6	EMC requirements.....	8
1.7	Software version.....	8
1.8	Materials.....	8
1.9	Natural refrigerant.....	8
1.10	Heat transfer liquid requirements.....	9
1.11	Hose requirements.....	9
1.12	Cooling water requirements.....	10
1.13	Environmental and operating conditions.....	10
1.14	Time limits.....	10
1.15	Warranty conditions.....	10
1.16	Copyright.....	10
1.17	Contact LAUDA.....	11
1.18	Safety features on the device.....	11
1.19	Structure of the warnings.....	11
1.20	Personnel qualification.....	12
1.21	Personal protective equipment.....	13
1.22	Warning symbols.....	13
2	Unpacking.....	15
3	Device description.....	16
3.1	Structure.....	16
3.1.1	Structure of Universa ECO immersion thermostat.....	16
3.1.2	Structure of Universa ECO heating thermostat.....	19
3.1.3	Structure of Universa ECO cooling thermostat.....	21
3.2	Operating elements.....	23
3.2.1	Buttons on the control panel.....	23
3.2.2	Mains switch.....	23
3.3	Functional elements.....	23
3.3.1	Standard and additional interfaces.....	23
3.3.2	Hydraulic circuit.....	24
3.3.3	Cooling unit.....	24
3.3.4	Bath edge ventilation.....	25

3.4	Type plates and serial numbers.....	25
4	Before starting up.....	29
4.1	Installing the device and accessories.....	29
4.1.1	Installing the pump and control unit.....	29
4.1.2	Installing the cooling coil.....	30
4.1.3	Installing the pump connector set.....	32
4.2	Install device.....	33
4.3	Hoses.....	37
4.4	LAUDA heat transfer liquids.....	38
4.5	Cooling water requirements.....	39
5	Commissioning.....	41
5.1	Establishing a mains connection.....	41
5.2	Display and navigation.....	43
5.3	Menu structure.....	44
5.4	Basic settings for commissioning.....	45
5.4.1	Sequence and limitation of inputs.....	45
5.4.2	Setting the temperature limits.....	45
5.4.3	Setting the set temperature.....	47
5.5	Filling the device.....	47
6	Operation.....	49
6.1	Safety instructions prior to operation.....	49
6.2	[COOL MODE] – Cooling unit operating mode.....	52
6.3	[SHUTDOWN TIMER] – Using the shutdown timer.....	53
6.4	[BATH TYPE] – Selecting the bath unit.....	55
6.5	[NETWORK] – Network, web server and cloud.....	55
6.5.1	View LAN configuration.....	56
6.5.2	Connecting the device to a wireless network (WLAN).....	57
6.5.3	[PC Control]– Operating the device using the Ethernet interface.....	59
6.5.4	Protocol of the interface.....	60
6.5.5	Read commands of the interface.....	61
6.5.6	Write commands of the interface.....	64
6.5.7	Web server LAUDA Command.....	64
6.5.8	LAUDA.LIVE cloud service.....	68
6.6	[INFO] – Further settings, information and software update.....	69
6.6.1	Set the date and time.....	70
6.6.2	Carrying out the software update.....	71
6.6.3	View software versions and serial numbers.....	72
6.7	[NOTIFICATIONS] – Displaying error messages.....	72
6.8	[CALIBRATION] – Calibrating the temperature probe.....	73

6.9	[RESTORE FAC. SET.] – Restoring the factory settings.....	75
7	Maintenance.....	77
7.1	Maintenance safety instructions.....	77
7.2	Maintenance intervals.....	78
7.3	Cleaning the air-cooled condenser.....	78
7.4	Check the heat transfer liquid.....	79
7.5	Check excess temperature and low-level protection device.....	81
8	Faults.....	82
8.1	Alarms, errors and warnings.....	82
8.2	Error messages.....	83
8.2.1	Excess temperature alarm A3.....	86
9	Decommissioning.....	88
9.1	Changing/draining heat transfer liquid.....	88
10	Disposal.....	89
10.1	Disposing of the refrigerant.....	89
10.2	Device disposal.....	89
10.3	Disposing of packaging.....	89
11	Technical data.....	90
11.1	General technical data.....	90
11.2	Stainless steel bath thermostats.....	92
11.3	Cold bath thermostats.....	94
11.4	Hydraulic data.....	94
11.5	Current consumption and heating output.....	96
11.6	Cooling capacity.....	97
11.7	Refrigerant and filling charge.....	97
11.8	Heating curves.....	98
11.9	Cooling curves.....	98
11.10	Pump characteristics.....	99
12	Accessories.....	100
13	Declaration of Conformity.....	102
14	Product Returns and Clearance Declaration.....	106
15	Index.....	107

1 Safety

1.1 General Information

Operating manual



IMPORTANT
READ CAREFULLY BEFORE USE
KEEP FOR FUTURE REFERENCE

- Read this operating manual carefully before use.
- All personnel must have read and understood the operating instructions before operating the device.
- Follow all the warnings and safety instructions on the device and in the operating manual.
- Always keep the operating manual within easy reach near the device.
- This operating manual is part of the device. Never pass the device on to third parties without the operating manual.
- The device must always be operated as intended according to the instructions in this operating manual. Any other use is considered to be unintended use. The manufacturer assumes no liability or guarantee for improper use.

Safe state

"Safe state" is understood to have the following meaning:

- It is the operating state of a system in which the risk to people, the environment or equipment is minimal.

The constant temperature equipment switches to the "safe state":

- in the event of overtemperature,
- if the liquid falls below the specified minimum level
- or if one or more errors or alarms occur.

Table 1: The "safe state" is indicated by:

Device	Heating off	Pump off	Visual signal	Acoustic signal
Universa ECO	✓	✓	✓	✓

1.2 Intended use

The devices can only be operated as intended under the conditions specified in this operating manual. Any other use is considered improper. It is the operator's responsibility to ensure that the devices are used properly.



Intended use

This device may only be used for controlling the temperature of non-flammable heat transfer liquids.

A heating and cooling thermostat is used for controlling the temperature of liquids in a bath vessel, and for controlling the temperature and circulating liquids in an external circuit.

A heating thermostat is used for heating heat transfer liquids in a bath vessel and for heating and circulating heat transfer liquids in an external circuit. The heating thermostat can be operated with a cooling coil. In this case, the heating thermostat can also be used to cool heat transfer liquids.

Reasonably foreseeable improper use

 DANGER! Ignition source placed in a hazardous atmosphere	
	Explosion
	<ul style="list-style-type: none"> Do not operate the device in hazardous areas.
 DANGER! Contact with live parts	
	Electric shock
	<ul style="list-style-type: none"> Do not operate the device outdoors.
 WARNING! The relevant standards are not observed	
	Personal injury
	<ul style="list-style-type: none"> Do not use the device for medical applications. Do not use the device in the food sector.

The following are considered cases of reasonably foreseeable misuse:

- Operating the device without heat transfer liquid
- Operating the device with a flammable heat transfer liquid
- Operating the device with an unsuitable heat transfer liquid
- Operating the pump and control unit without a bath unit or suspension device
- Medical applications
- Use in potentially explosive atmospheres
- Used for controlling the temperature of foodstuffs
- Outdoor installation
- Operation with an open consumer
- Operation with cables that are faulty, unsuitable or do not conform to standards
- Operation with faulty or unsuitable hoses
- Operation with the pump and control unit placed on the bath in a twisted position

The residual risks are described in the warnings and safety instructions in this operating manual.

1.3 Obligations of the operator

Observe the national regulations for operating the system in the country in which the system is installed.

In particular, the application of statutory regulations concerning operational safety must be observed.

1.4 Prohibition of modifications to the device

Any technical modification of the device by the user is prohibited. Any damage resulting from unauthorized modification is not covered by customer service or the product warranty. Service work may only be performed by the LAUDA Service department or a service partner authorized by LAUDA.

1.5 Observing additional operating instructions

Accessories

The device may be equipped with additional accessories, such as pump connections, cooling coils, etc. Before installing and using accessories, always read and observe the operating manual accompanying the relevant accessory.

1.6 EMC requirements

Table 2: Classification in accordance with EMC requirements

Device	Immunity requirements	Emissions class	Customer power supply
Universa ECO heating and cooling thermostats	Table 2 (industrial) in accordance with EN 61326-1	Emissions Class B in accordance with CISPR 11	Only for EU: See the following note
	Table 2 (industrial) in accordance with EN 61326-1	Emissions Class B in accordance with CISPR 11	Rest of the world (outside of EU): No limitation



For users in the European Union:

This device satisfies the EMC requirements of EN IEC 61326-1 as well as the flicker requirements of EN IEC 61000-3-11 section 4 a), provided that the maximum power supply impedance does not exceed 0.342 Ohm.

1.7 Software version

This operating manual is valid for LAUDA Universa ECO devices with software from the following version.

Software	Valid from version
Control system	1.04

1.8 Materials

All parts of the device that come into contact with heat transfer liquid are manufactured from high-quality materials adapted to withstand the operating temperature. High-quality stainless steels and high-quality, temperature-resistant plastics are used.

1.9 Natural refrigerant

The devices are filled with natural refrigerant.



The devices with natural refrigerant are permanently sealed systems, containing less than 0.15 kg of refrigerant from safety group A3. These refrigerants are highly flammable. Due to the low filling charge and permanently sealed design, there are no special installation requirements. The application area is only classified from a filling weight of over 0.15 kg, depending on the installation location and the requirements for using the space.

The refrigerant designation and charge are specified on the type plate and in the Chapter 11.7 “Refrigerant and filling charge” on page 97.

1.10 Heat transfer liquid requirements

The device is designed for non-flammable heat transfer liquids according to class division NFL as per DIN 12876.

- Heat transfer liquids are used to control the temperature.
- Heat transfer liquids from LAUDA are recommended. LAUDA heat transfer liquids are transfer liquids that have been tested and approved by LAUDA DR. R. WOBSER GMBH & CO. KG.
- The safety data sheet of the heat transfer liquid specifies potential hazards and the corresponding safety measures required for handling the liquid. The safety data sheet of the heat transfer liquid must therefore be observed to ensure proper use of the device.
- The heat transfer liquids are suitable for a specific temperature range. Select a heat transfer liquid with a temperature range suitable for the application.
- If you wish to use your own heat transfer liquids, you must check that the liquids are suitable for the materials used. The heat transfer liquid must be provided with corrosion protection. You must also test the suitability of the heat transfer liquid by performing a test run within the desired temperature range. During the test run, you must also check the low-level protection.
- Always use non-flammable heat transfer liquids.
- Do not use any heat transfer liquids that are radioactive, toxic or environmentally hazardous.
- Do not use deionized water as a heat transfer liquid.
- Use heat transfer liquids with a kinematic viscosity of less than 75 mm²/s during operation.
- Use heat transfer liquid with a density in the range of 0.95 to 1.2 g/cm³.
- Only use heat transfer liquids that are approved for heat transfer systems.

1.11 Hose requirements

The

- temperature,
- pressure and
- media resistance of the hoses must be suitable for the respective application.

Refer to Chapter 4.3 “Hoses” on page 37 for information on recommended hoses.

1.12 Cooling water requirements

Cooling water is subject to specific purity requirements. A suitable procedure must be employed to purify the cooling water in line with the contamination in the water and maintain the water quality.

1.13 Environmental and operating conditions

The device may only be used in the following areas:

- Production, quality assurance, research and development in an industrial environment
- Only used inside buildings
- Use up to a height of 2,000 m above sea level
- Ambient temperature from 5°C to 40°C
- Maximum relative humidity 80% at temperatures up to 31°C, linearly decreasing up to 50% relative humidity at 40°C
- Mains voltage fluctuations, for heating thermostats, see ↪ Chapter 11.1 “General technical data” on page 90 or for cooling thermostats ↪ Further information on page 91
- Transient electrical surges up to the values of surge category II
- Sporadic electric surges that occur in the mains power supply
- Pollution degree 2

1.14 Time limits

- | | |
|-----------------------|------------------------------------------------------|
| Service life | - All devices are designed for continuous operation. |
| Service life | - The device is designed for 20,000 operating hours. |
| Maintenance intervals | - ↪ Chapter 7.2 “Maintenance intervals” on page 78 |

1.15 Warranty conditions

LAUDA grants a standard warranty of one year.

1.16 Copyright

This operating manual was written in German, checked and approved. If the content of other language editions deviates from the German edition, the information in the German edition shall take precedence. If you notice any discrepancies in the content, please contact LAUDA Service, see ↪ Chapter 1.17 “Contact LAUDA” on page 11.

Company and product names mentioned in the operating manual are usually registered trademarks of the respective companies and are therefore subject to brand and patent protection. Some of the images used may also show accessories that are not included in the delivery.

All rights reserved, including those relating to technical modifications and translations. This operating manual or parts thereof may not be modified, translated or used in any other capacity without the written consent of LAUDA. Violation of this may obligate the violator to the payment of damages. Other claims reserved.

1.17 Contact LAUDA

Contact the LAUDA Service department in the following cases:

- Troubleshooting
- Technical questions
- Ordering accessories and spare parts

Please contact our sales department for questions relating to your specific application.

Contact information

LAUDA Service

Phone: +49 (0)9343 503-350

Email: service@lauda.de







1.18 Safety features on the device

Excess temperature and low-level protection

The device features an excess temperature and low-level protection device that turns off the heating and the pump independently of the temperature controller. The switch-off point is 125°C with a tolerance of -7 K.

If the bath temperature exceeds the excess temperature protection, or the fill level of the heat transfer liquid is too low, an alarm is triggered. In the process, all safety-related components on the device are switched off on all poles.

1.19 Structure of the warnings

Warning signs	Type of danger
	Warning – dangerous electrical voltage.
	Warning – explosive atmosphere.
	Warning – explosive substances.
	Warning – flammable substances.
	Warning – hot surface.
	Warning – slip hazard.
	Warning – danger zone.

Signal word	Meaning
DANGER!	This combination of symbol and signal word indicates an imminently dangerous situation that will result in death or serious injury if it is not avoided.
WARNING!	This combination of symbol and signal word indicates a potentially dangerous situation that can result in death or serious injury if it is not avoided.
CAUTION!	This combination of symbol and signal word indicates a possible dangerous situation that can result in minor injury if it is not avoided.
NOTICE!	This combination of symbol and signal word indicates a potentially dangerous situation that can result in material and environmental damage if it is not avoided.

	NOTICE! Origin of the hazard
	Possible consequences of the hazard
	<ul style="list-style-type: none"> ● Measure 1 ● Measure...

1.20 Personnel qualification

Certified specialist

Specialist who is certified and authorized to perform specific work.

Operating personnel

Operating personnel are personnel who have been instructed by qualified personnel on how use the device as intended in line with the information in the operating manual.

Specialized personnel

Certain activities on the device must be performed by specialized personnel. Specialized personnel are people whose professional education, knowledge, and experience as well as knowledge of relevant standards qualify them to assess the function and risks associated with the device and its use.

1.21 Personal protective equipment



Protective gloves

Protective gloves must be worn for certain tasks. The protective gloves must comply with standard DIN EN ISO 374-1. The protective gloves must be chemically resistant.



Protective work clothing

Protective clothing is required for the work. This must meet the legal requirements for personal protective equipment. The protective clothing should be long-sleeved. Do not wear rings, chains or other jewelry.



Safety glasses

Safety glasses must be worn for certain tasks. The safety glasses must comply with the standard DIN EN 166. The glasses must be tightly closed and equipped with side plates.



Safety gloves

The safety gloves are used to protect against injury when removing the outer housing panels and when removing components. The safety gloves must be chemical-resistant for work involving possible contact with temperature control fluid.



Safety shoes

Safety shoes are used to protect against heavy falling parts and slipping on slippery surfaces. They are also used to protect the feet when removing the outer housing panels..

1.22 Warning symbols

Stickers on refrigeration devices with NRTL certification, affixed on the right side of the device.

This equipment is intended for use in industrial occupancies as defined in the Safety Standard for Refrigeration Systems, ANSI/ASHRAE 15.

DANGER RISK Of Fire Or Explosion. FLAMMABLE REFRIGERANT Used. To Be Repaired Only By Trained Service Personnel. Do Not Use Mechanical Devices To Defrost REFRIGERATING EQUIPMENT. Do Not Puncture REFRIGERANT Tubing.

CAUTION RISK Of Fire Or Explosion. FLAMMABLE REFRIGERANT Used. Consult Repair Manual / Owner's Guide Before Attempting To Install Or Service This Equipment. All Safety Precautions Must be Followed. Dispose Of Properly In Accordance With Federal Or Local Regulations.

Cet équipement est destiné à être utilisé dans des établissements industriels tels que définis dans la norme de sécurité pour les systèmes de réfrigération, ANSI/ASHRAE 15.

DANGER RISQUE D'Incendie Ou D'Explosion. RÉFRIGÉRANT INFLAMMABLE Utilisé. À Réparer Uniquement Par Un Personnel De Service Formé. Ne Pas Utiliser D'Appareils Mécaniques Pour Dégivrer L'Équipement De Réfrigération. Ne Pas Percer La Tuyau De Réfrigérant.

ATTENTION RISQUE D'Incendie Ou D'Explosion. RÉFRIGÉRANT INFLAMMABLE Utilisé. Consulter Le Manuel De Réparation / Guide Du Propriétaire Avant De Tenter De Réparer Ce Produit. Toutes Les Précautions De Sécurité Doivent Être Suivies. Éliminer Correctement Conformément Aux Réglementations Fédérales Ou Locales.



Fig. 1

2 Unpacking

Personnel: Operating personnel

WARNING!
 Leaks in the cooling circuit due to transport damage

Fire	<ul style="list-style-type: none"> ● If you notice any damage to the transport packaging, store the device either in a well-ventilated place with no sources of ignition or outdoors. Contact LAUDA Service.
------	-----------------------------------------------------------------------------------------------------------------------------------------------------------------------------------------------------------------------------

- Wear protective gloves when unpacking.

The following instruction is relevant to heating thermostats:

- Place your hands under the device to lift and carry it.

The following instruction is relevant to cooling thermostats:

- Use the front and rear handles to lift and carry the unit.

1. Unpack the device.
2. Check that the device is complete and free of transport damage immediately after delivery.

Universa ECO standard accessories

Table 3: Universa ECO immersion thermostat

Designation	Quantity
Guard plate with screw clamp	1
Flow rate reducer for pump outlet	1
"Hot surface" warning sticker	1
Operating manual	1

Table 4: Universa ECO heating thermostat

Designation	Quantity
Flow rate reducer for pump outlet	1
"Hot surface" warning sticker	1
Operating manual	1

Table 5: Universa ECO cooling thermostat

Designation	Quantity
Bath cover	1
"Hot surface" warning sticker	1
Operating manual	1

3 Device description

3.1 Structure

3.1.1 Structure of Universa ECO immersion thermostat

Front view

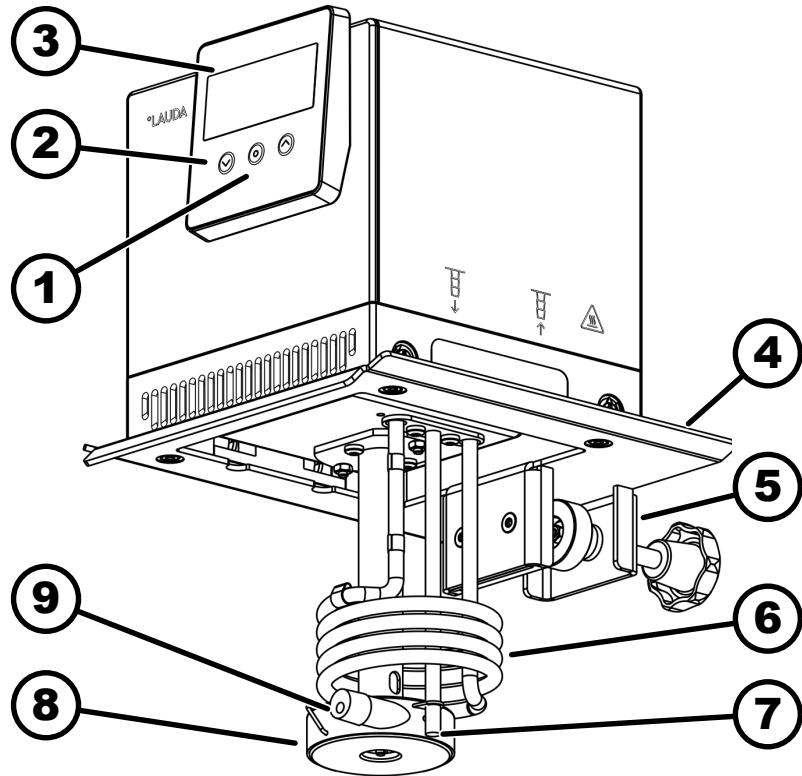

Fig. 2: Universa ECO immersion thermostat

- 1 Enter key
- 2 Arrow key (up and down)
- 3 Display
- 4 Guard plate
- 5 Screw clamp
- 6 Heater
- 7 Temperature probe (Pt100)
- 8 Pump housing with impeller
- 9 Flow rate reducer for the pump outlet

Rear view (voltage variant 200–240 volts)

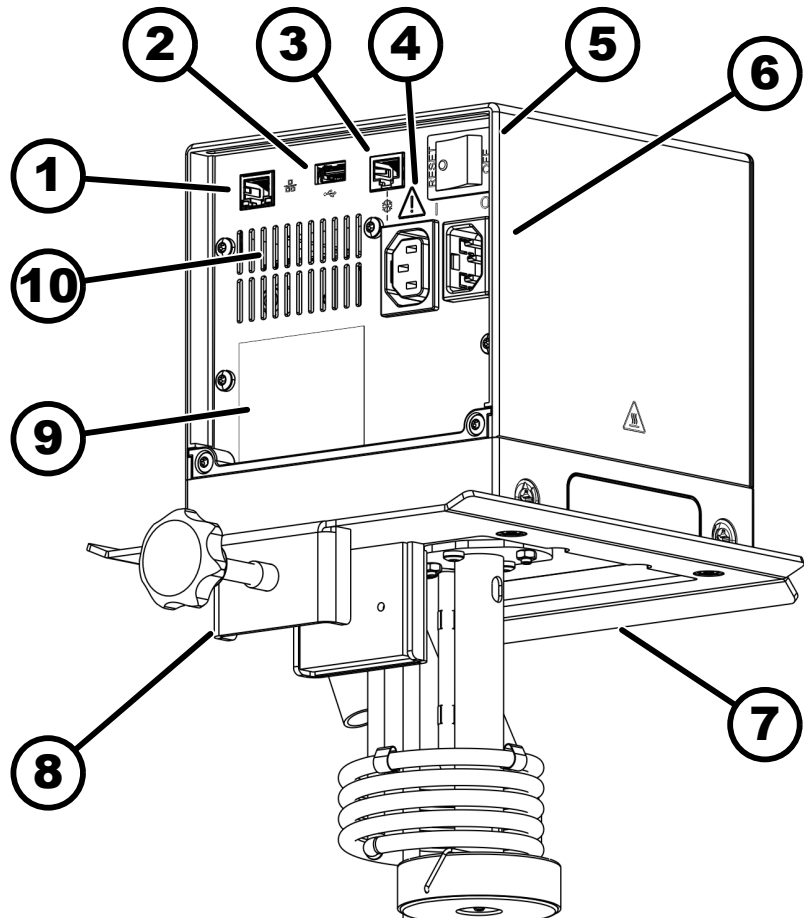

Fig. 3: Universa ECO immersion thermostat, rear view

- 1 Ethernet interface (RJ45 socket)
- 2 USB interface for software updates
- 3 Connection socket (RJ45 socket) for cold bath control cable
- 4 High resistance socket for pump and control unit power supply for cold bath
 ⚠ *Connecting assemblies other than LAUDA Universa cold baths is not permitted! The maximum current must not exceed 10 amperes.*
- 5 Mains switch (with circuit breaker)
- 6 Power supply via high resistance socket
- 7 Guard plate
- 8 Screw clamp
- 9 Pump and control unit type plate
- 10 Safety temperature limiter (STL) button

Rear view (voltage variant 100–125 volts)

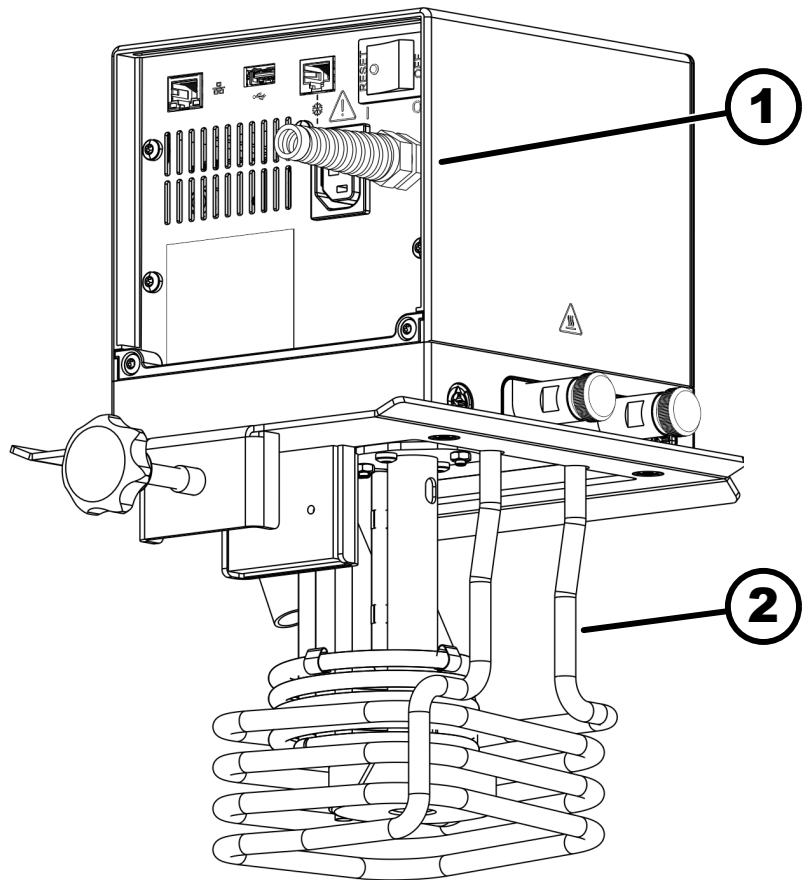

Fig. 4: Universa ECO immersion thermostat, rear view

- 1 Power cord, not interchangeable
- 2 Cooling coil with connection sleeve (optional accessory for all heating thermostats)

3.1.2 Structure of Universa ECO heating thermostat

Front

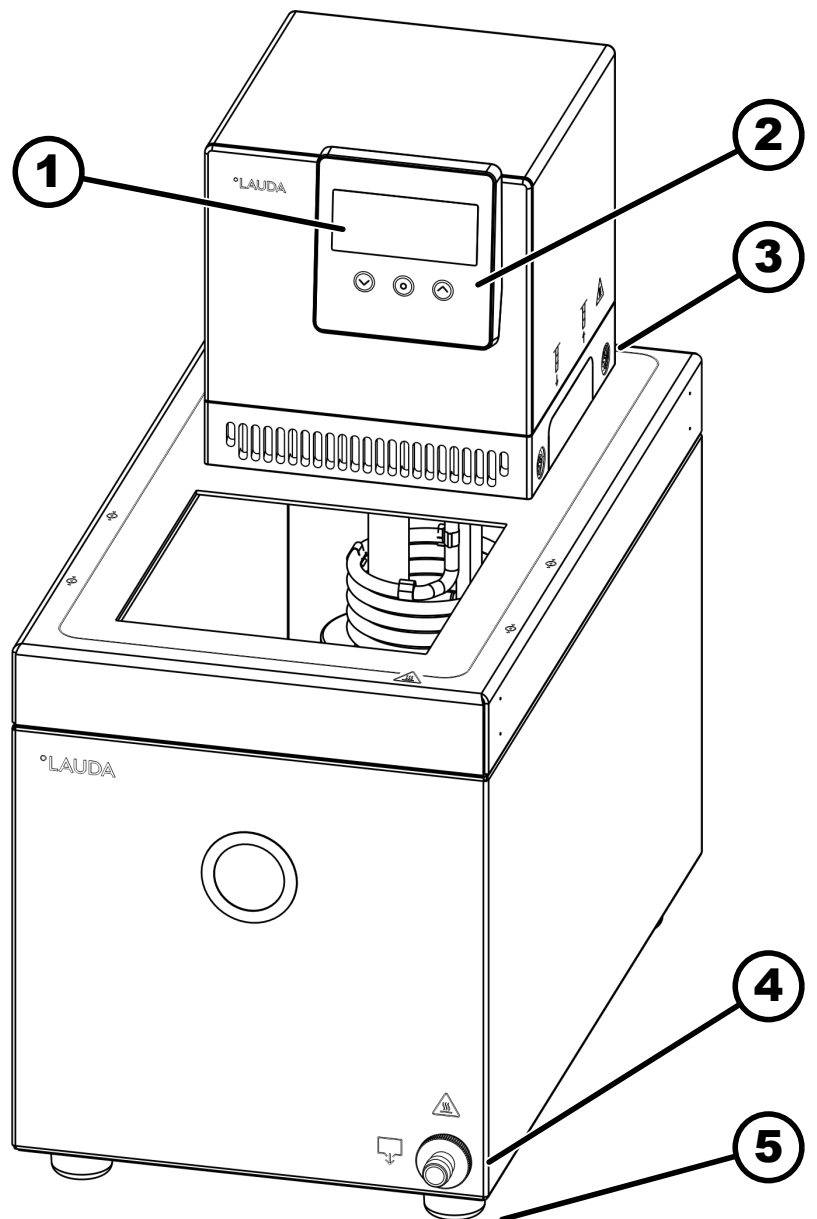

Fig. 5: Universa ECO heating thermostat, front view

- 1 Display
- 2 Control panel
- 3 Four locks on the pump and control unit on the bath bridge
- 4 Drain nozzle with drain tap
- 5 Four feet

Back

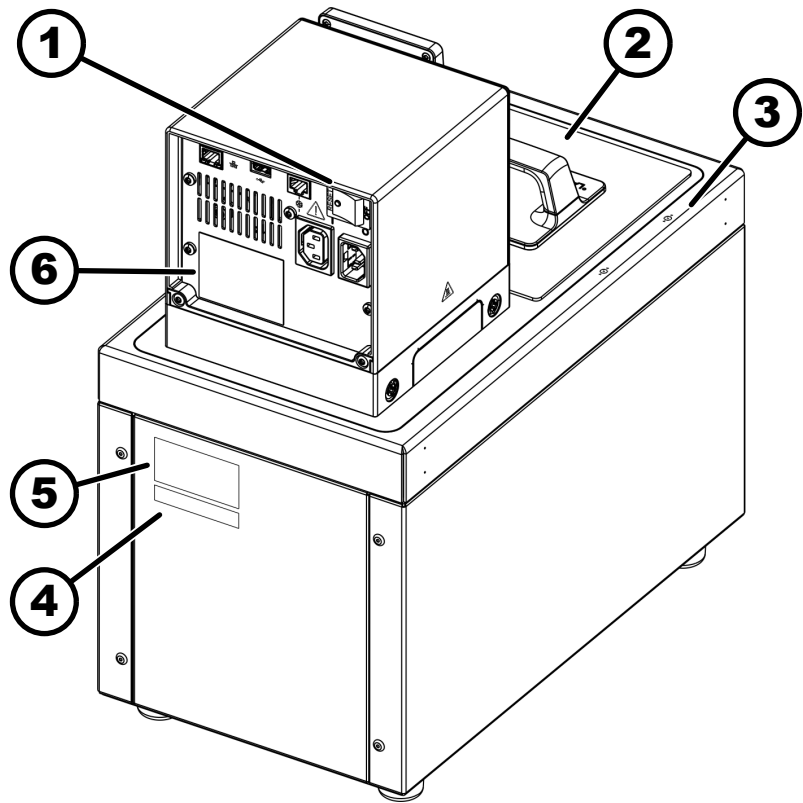

Fig. 6: Universa ECO heating thermostat, rear view

- 1 Mains switch (circuit breaker)
- 2 Bath cover (optional accessory)
- 3 Markings for holes in bath edge
- 4 Complete system type plate
- 5 Stainless steel bath type plate
- 6 Pump and control unit type plate

3.1.3 Structure of Universa ECO cooling thermostat

Front

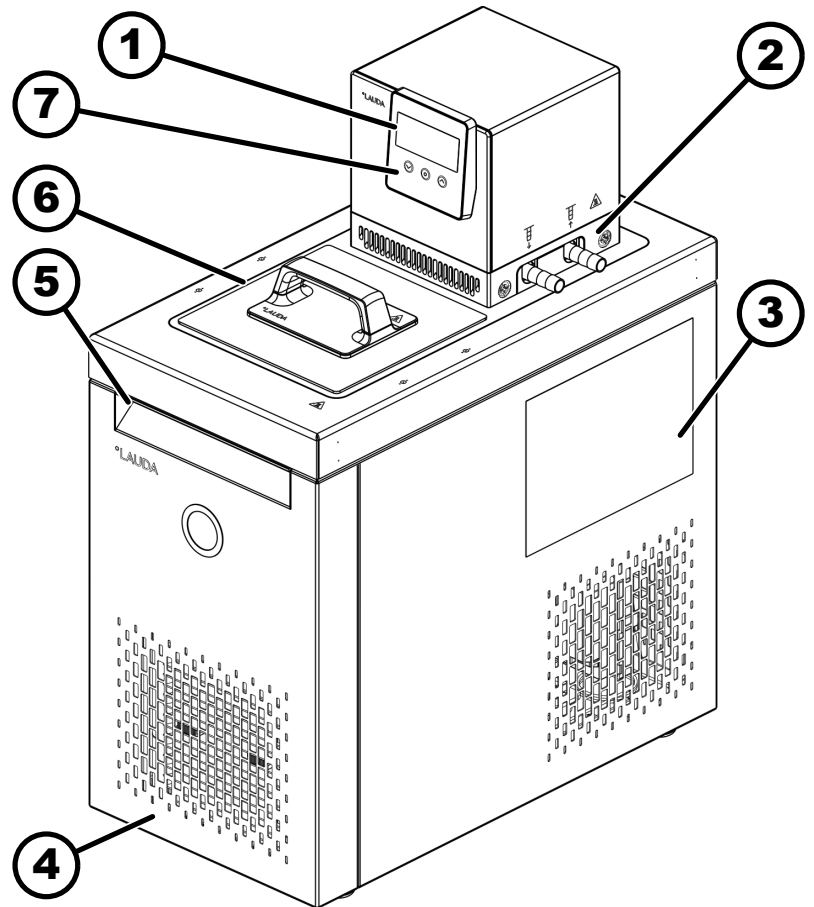

Fig. 7: Universa ECO cooling thermostat, front view

- 1 Display
- 2 Connection for application (inlet on left and outlet on right)
- 3 Stickers on devices with NRTL certification
- 4 Front panel (detachable), underneath a drain nozzle with drain tap
- 5 Recessed grip, front
- 6 Bath cover
- 7 Control panel

Back

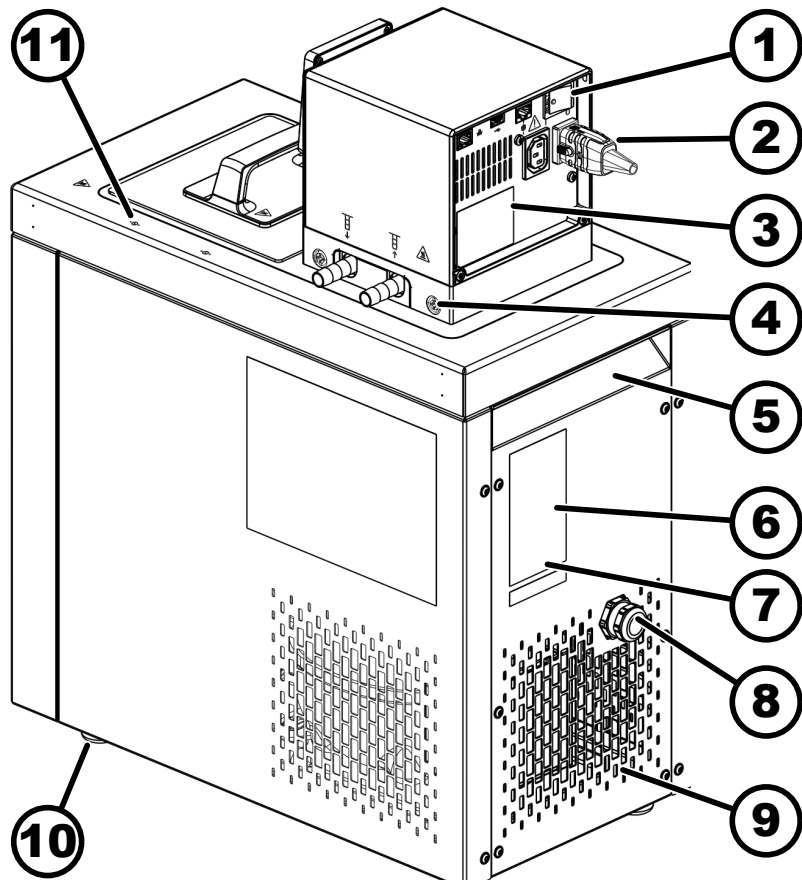

Fig. 8: Universa ECO cooling thermostat, rear view

- 1 Mains switch (with circuit breaker)
- 2 Power supply line
- 3 Pump and control unit type plate
- 4 Four locks on the pump and control unit on the bath bridge
- 5 Recessed grip, rear
- 6 Cold bath type plate
- 7 Complete system type plate
- 8 Cables for the cold bath's control and power supply *
- 9 Ventilation grid
- 10 Four feet
- 11 Markings for holes in bath edge

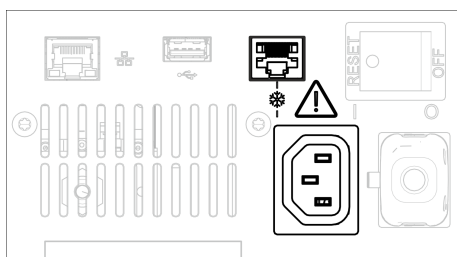

Fig. 9: Sockets for connecting the cold bath cables

* Cables not shown. Connect both cables for the cold bath's control and power supply to the pump and control unit. A snowflake symbol on the rear of the pump and control unit indicates the corresponding sockets.

3.2 Operating elements

3.2.1 Buttons on the control panel

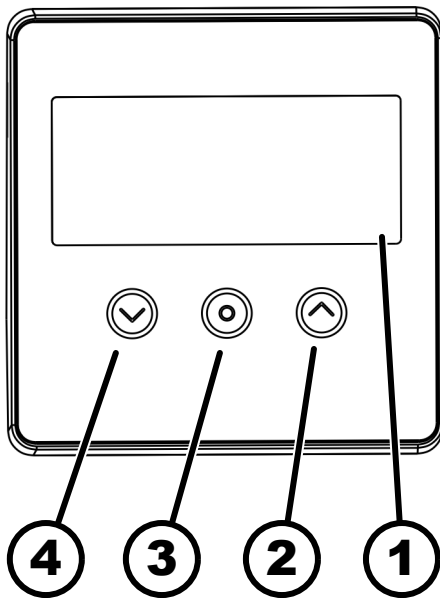

Fig. 10: Control panel

- 1 Display
- 2 Up arrow key, for settings and menu navigation
- 3 Enter key
- 4 Down arrow key, for settings and menu navigation

The buttons can be used to control the following functions on the device display:

- With the Enter key:
 - Select menu items and confirm settings.
 - On the home screen in the [T INT] menu item: Choose between the two operating modes: [STOPPED] (standby) and [RUNNING] (operation).
 - Confirm messages
- With the down arrow key:
 - Navigate through the device menu.
 - Change settings and numerical values.
- With the up arrow key:
 - Navigate through the device menu.
 - Change settings and numerical values.
 - Navigate back to the higher-level menu.

3.2.2 Mains switch

The device is fitted with a mains switch. Position [0] switches the device off, position [1] switches it on.



The rocker switch is also designed as a safety switch. If the current is too high, the rocker switch trips and disconnects the device from the mains supply. The device can be used again by switching the rocker switch to position [1]. If the rocker switch trips again, contact the LAUDA Service department ↗ Chapter 1.17 “Contact LAUDA” on page 11.

3.3 Functional elements

3.3.1 Standard and additional interfaces

The following sections contain a general overview of the standard interfaces on the device. Universa ECO devices cannot be equipped with additional interface modules.



Equipment connected to the low-voltage inputs and outputs must be safely insulated against dangerous contact voltages as per DIN EN 61140, for example, using double or reinforced insulation as per DIN EN 60730-1 or DIN 60950-1.

Standard interfaces



The USB interface is not designed for connecting a device (laptop, smartphone) but only for USB memory sticks.

- The **Ethernet interface** allows connection to a control station or PC. The interface offers the user the opportunity to control and monitor their temperature control processes via a LAUDA interface command set (process interface). Furthermore, the Ethernet interface can also be used for connecting to the cloud and for accessing the device's web server.
- The **USB interface host** (type A) is not a process interface. It enables a USB stick to be connected and can be used for:
 - Software updates
 - Transmitting login information for a WLAN connection with a pre-shared key (WPA-PSK).

3.3.2 Hydraulic circuit

Hydraulic circuit

The hydraulic circuit refers to the circuit containing the heat transfer liquid.

The circuit essentially consists of the following components:

- **Bath vessel** containing heat transfer liquid with integral cooling (for cooling thermostats)
- **Pump**
 - The pump circulates the heat transfer liquid inside the bath vessel, and achieves a homogeneous temperature distribution.
 - The pump operates at a set speed. The pump volume flow can be reduced with the aid of a flow rate reducer. The flow rate reducer prevents the heat transfer liquid from overflowing in small baths.
 - The pump's discharge nozzle can be closed without disturbing the pump.
 - During operation without a (silicone) pump link, the heat transfer liquid can be circulated via the pump connectors (optional accessory) in the external application.
- **Heater** for heating the heat transfer liquid
- **Cooling coil** for cooling the heat transfer liquid (optional accessory for immersion thermostats and heating thermostats).
- **Hoses** to external **application** and back (optional accessory).

Cooling coil in the bath

- A cooling source such as a fresh water supply is connected to the cooling coil connection sockets.
- The bath temperature of the thermostat can be decreased to approximately 5 °C above the temperature of the cooling water (without an external application).

3.3.3 Cooling unit



The cooling unit contains natural refrigerant, which is flammable.

The cooling unit consists of the following main components:

■ **Compressor**

The compressor's speed is variable and can be controlled as required. During operation, the compressor switches on automatically but can also be activated manually via the control menu, see (↗ Chapter 6.2 "[COOL MODE] – Cooling unit operating mode" on page 52). If safety-related faults occur, the compressor is switched off automatically.

■ **Evaporator**

A stainless steel tube coil evaporator extracts the heat from the internal bath.

3.3.4 Bath edge ventilation

The air flowing from the pump and control unit is directed over the edge of the bath to reduce any excessive cooling or heating of the bath edge when the bath is already cooled or heated. Depending on the operating status, this may reduce ice formation and condensation on the bath edge.

During operation, the ventilation in the pump and control unit runs continuously and unregulated at a fixed speed. Ventilation is not active when the device is switched off, in standby mode or if an alarm has been triggered.

3.4 Type plates and serial numbers

The bath thermostats from the LAUDA Universa product line are designed for a modular structure. The heating and cooling thermostats consist of a pump and control unit as well as a bath unit, which can be flexibly combined.

Both the pump and control unit and the bath units have separate type plates. The type plates contain important key data and other useful information.

Pump and control unit type plate

The pump and control unit is a separate assembly that can be mounted on a bath unit. Each pump and control unit has a separate type plate, which contains the following information. Certain specifications depend on the equipment installed.

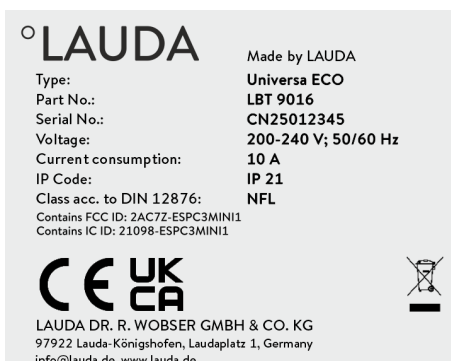

Table 6: For a pump and control unit:

Specification	Description
Type:	Type designation of the pump and control unit
Part No.:	Item number of the pump and control unit
Serial No.:	■ Serial number of the pump and control unit consisting of: <ul style="list-style-type: none"> ● the letters CN, ● the year of manufacture (indicated by two digits), ● a 6-digit number.
Voltage:	Permissible mains voltage and mains frequency of the pump and control unit

Fig. 11: Type plate of a pump and control unit

Specification	Description
Current consumption:	Current consumption of the pump and control unit (maximum value including connected cold baths)
IP Code:	Protection level of the casing according to EN 60529
Class acc. to DIN 12876	Class division according to DIN 12876
For devices with an integral WLAN module:	
Contains FCC ID:	Identifier for approval of devices with a WLAN module in the USA.
Contains IC ID:	Identifier for approval of devices with a WLAN module in Canada.

Bath unit type plate



Fig. 12: Type plate of a stainless steel bath

The bath unit of the heating and cooling thermostat is a separate assembly that has its own type plate containing the following information. Certain specifications depend on the equipment installed.

Table 7: For a heating thermostat:

Specification	Description
Type:	Type designation of the stainless steel bath
Part No.:	Item number of the stainless steel bath
Serial No.:	<ul style="list-style-type: none"> ■ The serial number of the stainless steel bath consists of: <ul style="list-style-type: none"> ● the letters CN, ● the year of manufacture (indicated by two digits), ● a 6-digit number.



		Made by LAUDA
Type:	U 830	
Part No.:	BUK 271	
Serial No.:	CN25012345	
Refrigerant:	R-600a	
Filling charge:	30 g	
PS high pressure:	10 bar	
PS low pressure:	4 bar	
Voltage:	220-240 V; 50/60 Hz	
Current consumption:	1,9 A	
IP Code:	IP 21	
Refrigeration equipment with flammable refrigerant		
		
LAUDA DR. R. WOBSE GMBH & CO. KG 97922 Lauda-Königshofen, Laudaplatz 1, Germany info@lauda.de, www.lauda.de		

Fig. 13: Type plate of a cold bath

Table 8: For a cooling thermostat:

Specification	Description
Type:	Type designation of the cold bath
Part No.:	Item number of the cold bath
Serial No.:	<ul style="list-style-type: none"> ■ The serial number of the cold bath consists of: <ul style="list-style-type: none"> ● the letters CN, ● the year of manufacture (indicated by two digits), ● a 6-digit number.
Refrigerant:	Refrigerant used in the device's cooling circuit.
Filling charge:	Filling weight of refrigerant in the cooling circuit.
PS high pressure:	Maximum permissible operating pressure on the high-pressure side of the cooling circuit (compression, condensation).
PS low pressure:	Maximum permissible operating pressure on the low-pressure side of the cooling circuit (expansion, evaporation).
Voltage:	Permissible mains voltage and mains frequency of the cold bath
Current consumption:	Current consumption of the cold bath
IP Code:	Protection level of the casing according to EN 60529
Refrigeration equipment with flammable refrigerant	Note: Refrigeration device containing flammable refrigerant



Power supply for cooling thermostats

Before connecting a device to the mains power, always compare the mains voltage and mains frequency with the type plate on the pump and control unit and with the type plate on the cold bath.

If the specifications for the permissible mains voltage range of the pump and control unit and the cold bath are different, the overlapping range applies. The mains voltage and frequency must be within this range.

Serial number for the overall system

A LAUDA Universa heating and cooling thermostat is a complete system consisting of a pump and control unit as well as a bath unit. This complete system is assigned a separate serial number in the factory, which is indicated on an additional label on the bath unit. This serial number is provided as a means of identifying the complete system.

Complete system	
Type:	U 830 E
Part No.:	L004286
Serial No.:	CN25012345

Fig. 14: Type plate of a cooling thermostat

Table 9: For a complete system

Specification	Description
Type:	Type designation of the heating and cooling thermostat
Order No.:	Item number of the heating and cooling thermostat
Serial No.:	<ul style="list-style-type: none"> ■ The serial number of the heating and cooling thermostat consists of: <ul style="list-style-type: none"> ● the letters CN, ● the year of manufacture (indicated by two digits), ● a 6-digit number.

4 Before starting up

4.1 Installing the device and accessories

4.1.1 Installing the pump and control unit

The following section describes how to install the pump and control unit on a bath unit. The devices are usually delivered in an assembled state. The pump and control unit is fastened to the bath bridge with rotary locks on locking bolts.



- Before placing the pump and control unit on the bath unit, make sure that all rotary locks are open (arrow on the rotary lock is pointing upwards).
- When placing the pump and control unit on the bath unit, make sure that the components in the lower area of the unit and any attached accessories do not get caught in the bath bridge opening.

- Personnel: ■ Specialized personnel
- Protective equipment: ■ Protective work clothing
■ Safety gloves
■ Safety shoes
- Tool: ■ Allen wrench 4 mm **or**
cross-head screwdriver PZ2

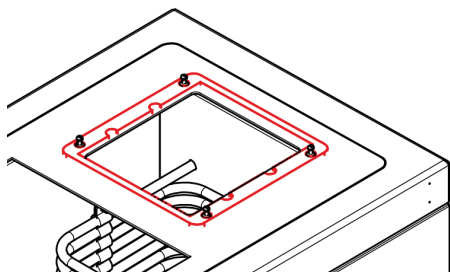

1. Place a flange gasket in the area of the locking bolts (LAUDA part number: EDF 480) on the bath edge.



The inner indentations in the flange gasket are not arranged centrally. Make sure that the side with the shorter distance between the indentations and the outer edge of the flange gasket is facing forward towards the bath opening.

2. Carefully guide the heater and pump in the lower area of the pump and control unit through the bath opening and place the unit on the bath unit.



When positioning the pump and control unit, make sure that the gasket is fitted correctly between the bath edge and the pump and control unit. The gasket should fit correctly in the indentation on the underside of the pump and control unit without being squashed in the gap between the unit and the bath edge.

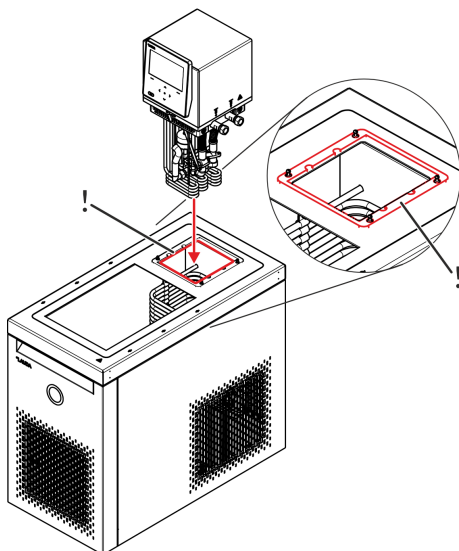

3. Turn the two rotary locks on the right- and left-hand side of the pump and control unit using a 4-mm Allen wrench or a PZ2 cross-head screw driver:

- To close the lock - Turn the rotary lock in a clockwise direction until the pump and control unit is fitting tightly, as far as you can until the arrow on the lock is pointing upwards.

To open the lock - Turn the rotary lock in a counterclockwise direction until the arrow on the lock is pointing downwards.



The arrow on the rotary locks indicates the direction of rotation for closing.

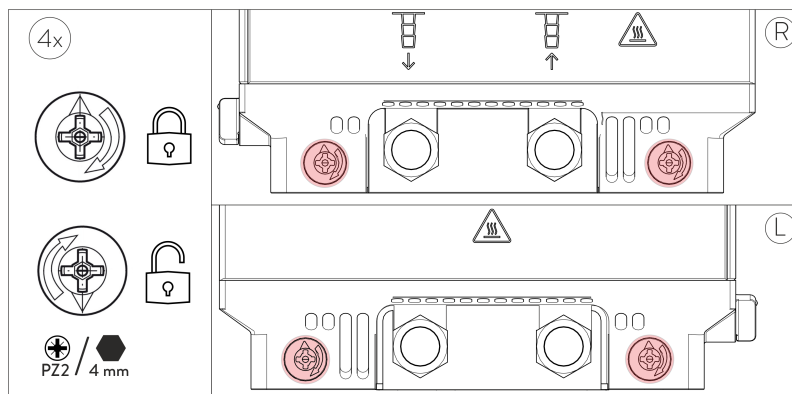

4.1.2 Installing the cooling coil

The following section describes how to install a cooling coil using the example of the Universa PRO pump and control unit. For this purpose, you need to remove a blind flange from the intermediate plate and replace it with the cooling coil and a sealing flange. The installation does not require any tools.



Installation position

The cooling coil has a symmetrical structure and can therefore be mounted on the left- or right-hand side of the pump and control unit. However, depending on the bath type, it will only be possible to install it on one side.

1. Remove any residual heat transfer liquid from the unit and make sure that the unit is clean and dry. Place the pump and control unit upside down on a stable and non-slip support.

Make sure that the operating panel is protruding over the support and that the unit is lying flat.

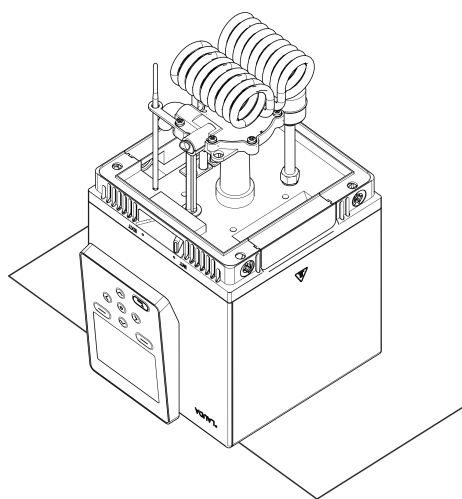

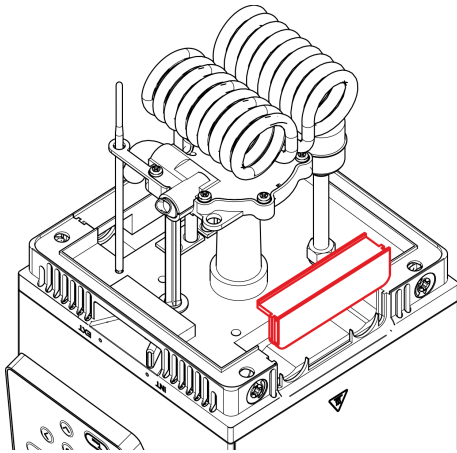

2. Pull the blind flange out of the intermediate plate.

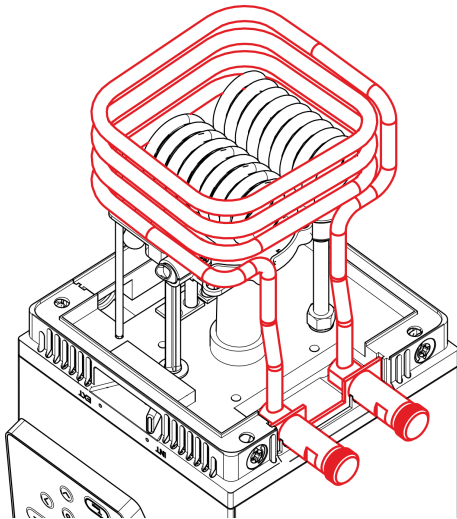

3. Insert the cooling coil into the intermediate plate.

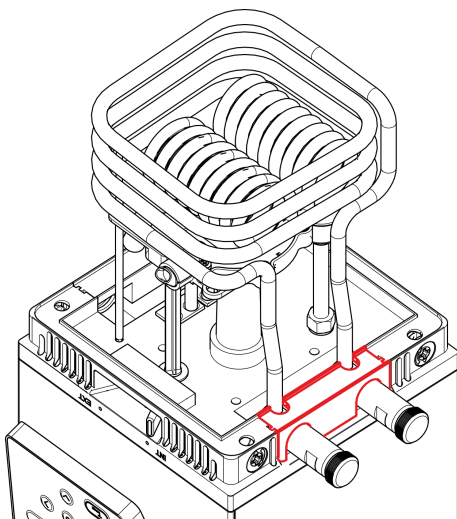

4. Push the sealing flange with the recesses onto the intermediate plate.
5. Install the pump and control unit onto the bath or, in the case of an immersion thermostat, onto the guard plate, see chapter [Chapter 4.1.1](#) "Installing the pump and control unit" on page 29.

4.1.3 Installing the pump connector set

The following section describes how to install a pump connector set using the example of the Universa ECO pump and control unit. To do this, you need to remove a blind flange from the intermediate plate and replace it with the pump connector set and a sealing flange. The installation does not require any tools.

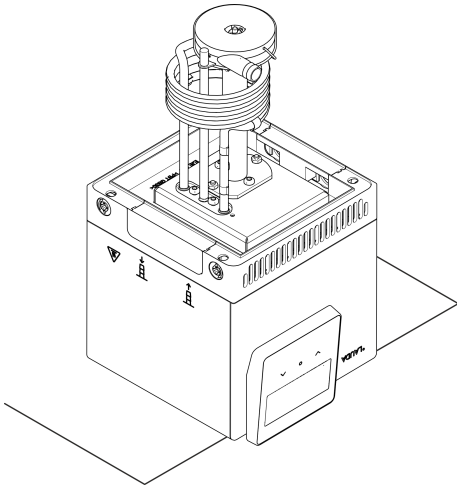

1. Remove any residual heat transfer liquid from the unit and make sure that the unit is clean and dry. Place the pump and control unit upside down on a stable and non-slip support.

Make sure that the operating panel is protruding over the support and that the unit is lying flat.

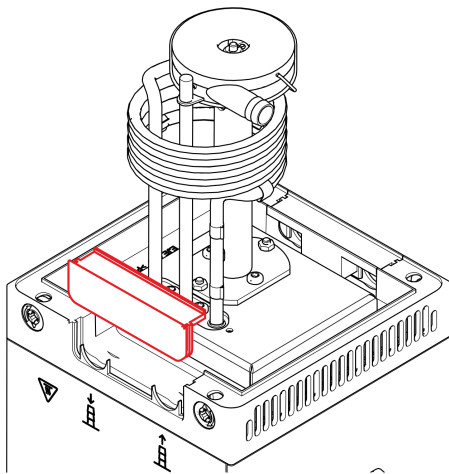

2. Pull the blind flange out of the intermediate plate.

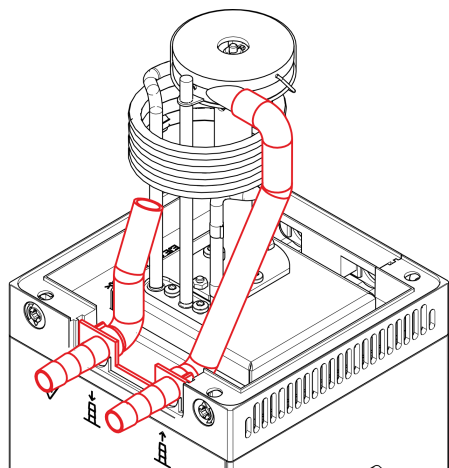

3. Insert the pump connector set into the intermediate plate and push the hose on the outflow connector onto the pump outlet.



- Before pushing on the hose, remove a flow rate reducer on the pump outlet if necessary.
- Before pushing on the hose, clean the hose nozzle at the pump outlet if necessary.
- A hose clamp or similar mounting material should *not* be used at this point.

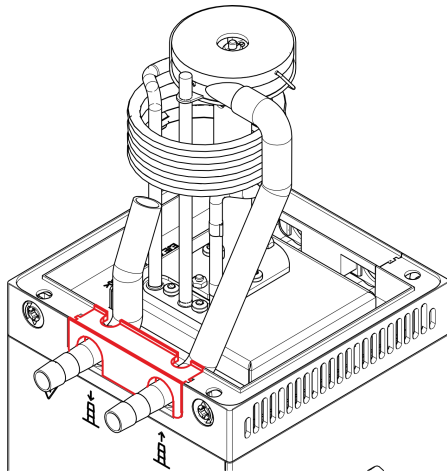

4.2 Install device



4. Push the sealing flange with the recesses onto the intermediate plate.
5. Install the pump and control unit onto the bath or, in the case of an immersion thermostat, onto the guard plate, see chapter ↗ Chapter 4.1.1 “Installing the pump and control unit” on page 29.

Each cooling circuit of Universa cooling thermostats contains less than 150 g of flammable refrigerant.

- According to standard EN 378-1, permanently sealed refrigeration systems below this filling limit are not subject to any special requirements regarding installation location, room volume or access area.



DANGER!

Contact with voltage conductors due to faulty power supply cable

Electric shock

- Always use standard power supply cables such as the one supplied.
- Check the supplied power supply cable for damage prior to use.



DANGER!

The cold appliance coupling detaches from the built-in connector

Electric shock

- Insert the built-in connector until the lock engages.



WARNING!

Distribution box / multiple socket is unsuitable

Fire

- Only connect the device directly to the socket on the installation side.
- Do not use distribution boxes or multiple sockets.



WARNING!
Danger of the device rolling away or overturning

Impact, crushing

- Do not tilt the device!
- Position the device on an even, non-slip surface with a sufficient load carrying capacity!
- Do not position the device close to table edges.
- Actuate the caster brake when setting up the device!
- Do not place heavy parts on the device!



WARNING!
Danger of overpressure if ambient temperature is too high

Injury, escape of refrigerant, fire

- Note the permissible ambient temperature and storage temperature.



WARNING!
Risk of heat transfer liquid leaking

Scalding, cold burns

- Do not store any liquids or objects above the device.



WARNING!
Risk of heat transfer liquid leaking

Scalding, cold burns

- The temperature and media resistance of the hoses must be suitable for the application.
- Use hoses with a greater compressive strength than the maximum possible pump pressure. For liquids with a density above 1 kg/dm^3 , the pump pressure must be converted according to the density.
- Use pressure-resistant external applications or safety valves in the hydraulic circuit.
- When laying the hoses for the application, make sure that the hoses cannot be kinked or crushed.
- Always secure the hoses with suitable hose safety devices.



WARNING!
Contact with hot or cold hoses

Hot and cold burns

- Use insulated hoses for temperatures below 0 °C and above 70 °C.



WARNING!
Risk of heat transfer liquid escaping during operation with an open consuming unit

Scalding, cold burns

- Always use hydraulically sealed consuming units.



WARNING!
Bursting of the external consuming unit due to excessive pressure

Scalding, cold burns

- If the external consuming unit is located in a lower position and is sensitive to pressure, also take into account the additional pressure resulting from the difference in height between the consuming unit and the device.
- For pressure-sensitive consuming units (for example, glass apparatus) with a maximum permissible operating pressure below the maximum pressure of the pump (see Technical Data section), the hoses of the consuming unit must be laid in such a way that bending or squeezing is not possible.
- A separate safety valve must be installed in the outflow to protect against operating errors.



WARNING!
Use of unsuitable heat transfer liquid

Fire, mutation, poisoning, environmental hazard, equipment damage

- Heat transfer liquids from LAUDA are recommended.
- If you wish to use your own heat transfer liquids, you must check that the liquids are suitable for the materials used. The heat transfer liquid must be provided with corrosion protection. You must also test the suitability of the liquid by performing a test run within the desired temperature range. During the test run, you must also check the low-level protection.
- Select a heat transfer liquid with a temperature range suitable for the application.
- Only ever use non-flammable heat transfer liquids.
- Do not use any heat transfer liquids that are radioactive, toxic or environmentally hazardous.
- Do not use deionized water as a heat transfer liquid.
- Only use heat transfer liquids that are approved for heat transfer systems.
- Do not use heat transfer liquids with a kinematic viscosity above 75 mm²/s during regular operation.
- Use heat transfer liquids with a density in the range of 0.95 to 1.2 g/cm³.

- Personnel: ■ Specialized personnel
- Protective equipment: ■ Protective work clothing
 ■ Safety glasses
 ■ Protective gloves

Connecting an external application

1. Please note the following:
 - When connecting the hoses:
 - Remove the (silicone) pump link from the outflow and outlet of the pump connector.
 - Secure the hoses with hose clamps on the outflow and outlet of the pump connector.
 - Use the shortest possible hoses with the largest possible diameter. If the diameter of the hose is too small or too long, the temperature will drop between the constant temperature equipment and the external application due to the low flow rate.
 - If the application is positioned higher than the constant temperature equipment, the following can happen:
 - Air can enter the external fluid circuit when the pump is not in operation,
 - which can allow liquid to flow from the application into the constant temperature equipment even though the circuit is sealed,
 - resulting in the liquid in the constant temperature equipment overflowing.

Disconnecting an external application

2. If the constant temperature equipment is disconnected from the external application,
 - the outflow and outlet of the pump connector at the constant temperature equipment must be connected with a pump link,

4.3 Hoses

Approved elastomer hoses

Hose type	Clear Ø in mm	Outer diameter in mm	Temperature range of the hose in °C	Application area	Part number
EPDM hose, not insulated	9	13	10 – 90	for all LAUDA heat transfer liquids approved for Universa ECO	RKJ 111
EPDM hose, not insulated	12	16	10 – 90	for all LAUDA heat transfer liquids approved for Universa ECO	RKJ 112
EPDM hose, insulated	12	35	-35 – 90	for all LAUDA heat transfer liquids approved for Universa ECO	LZS 021
Silicone hose, not insulated	11	15	10 – 100	Water, water-glycol mixture	RKJ 059
Silicone tube, insulated	11	33	-60 – 100	Water, water-glycol mixture	LZS 007

4.4 LAUDA heat transfer liquids

Please note:

- If the heat transfer liquid reaches the lower limit of the temperature range, the temperature control properties can be expected to deteriorate as a result of the increase in viscosity. Therefore, only fully utilize this temperature range when absolutely necessary.
- Never use contaminated heat transfer liquids. Contamination in the pump housing can cause the pump to seize and the device to shut down.
- Observe the safety data sheet for the heat transfer liquid. You can request a copy of the safety data sheets at any time, if necessary.

Table 10: Approved heat transfer liquids

Designation	Chemical name	Working temperature range in °C	Viscosity (kin) in mm ² /s (at 20 °C)	Viscosity (kin) in mm ² /s at temperature	Flash point in °C
Aqua 90	Decalcified water	5–90	1	---	---
Kryo 10	Water-propylene glycol mixture	-10 – 90	4.3	14 at -10 °C	---
Kryo 15	Water/monoethylene glycol mixture	-20 – 90	2.62	17.63 at -20°C	---
Kryo 30	Water/monoethylene glycol mixture	-30 – 90	4	50 at -25 °C	---

- When using Kryo 30, Kryo 15 and Kryo 10:
The water content decreases during longer periods of operation at higher temperatures, and the mixture becomes flammable.
The flash point of the glycol used in the heat transfer liquid:
 - Monoethylene glycol (Kryo 30, Kryo 15): 119°C
 - Propylene glycol (Kryo 10): 104°C
 Check the mixing ratio using a hydrometer, for example.
- Evaporation losses occur at higher temperatures. In this case, use a bath cover.

Table 11: Heat transfer liquid part numbers

Designation	Container size			
	Part number			
	5 L	10 L	20 L	200 L
Aqua 90	LZB 120	LZB 220	LZB 320	---
Kryo 10	LZB 132	LZB 232	LZB 332	LZB 832
Kryo 15	LZB 133	LZB 233	LZB 333	LZB 833
Kryo 30	LZB 109	LZB 209	LZB 309	LZB 809

Heat transfer liquid, water

- The proportion of alkaline earth ions in the water must be between 0.71 mmol/L and 1.42 mmol/L (equivalent of 4.0 °dH and 8.0 °dH). Harder water leaves limescale deposits in the device.
- The pH value of the water must be between 6.0 and 8.5.
- Distilled, deionized and demineralized water are unsuitable due to their reactivity. High-purity water and distillates are suitable as a heat transfer liquid after 0.1 g of soda (Na_2CO_3 , sodium carbonate) is added for every liter of water.
- Sea water is unsuitable due to its corrosive properties.
- Avoid chlorine in the water at all costs. Do not add chlorine to the water. Cleaning agents and disinfectants, for example, contain chlorine.
- The water must be free of impurities. Water with iron content is unsuitable due to rust formation and untreated river water is unsuitable due to algae growth.
- The addition of ammonia is not permitted.

4.5 Cooling water requirements

Requirements

Cooling water is subject to specific purity requirements. A suitable procedure must be employed to purify the cooling water in line with the contamination in the water and maintain the water quality. Unsuitable cooling water may cause the condenser and the entire cooling water circuit to become blocked or damaged, or start to leak. The entire cooling circuit and cooling water circuit may sustain extensive consequential damage as a result.

- Free chlorine consisting of disinfectant, for example, and water containing chloride will cause pitting corrosion in the cooling water circuit.
- Distilled, deionized and demineralized water are unsuitable due to their reactivity and will cause corrosion in the cooling water circuit.
- Sea water is unsuitable due to its corrosive properties and will cause corrosion in the cooling water circuit.
- Iron particles and water containing iron will cause corrosion in the cooling water circuit.
- Hard water is unsuitable for cooling due to the high lime content and will lead to calcification of the cooling water circuit.
- Cooling water containing suspended matter is unsuitable.
- Untreated, unpurified water such as river water or cooling tower water is unsuitable due to its microbiological content (bacteria), which can settle inside the cooling water circuit.

Suitable cooling water quality

Data	Value	Unit
pH value	7.5 – 9.0	---
Hydrocarbonate [HCO_3^-]	70 – 300	mg/L
Chloride	< 50	mg/L
Sulfate [SO_4^{2-}]	< 70	mg/L
Ratio hydrogen carbonate [HCO_3^-] / sulfate [SO_4^{2-}]	> 1	---

Data	Value	Unit
Total water hardness	4.0 – 8.5	°dH
Electrical conductivity	30 – 500	µS/cm
Sulfite (SO ₃ ²⁻)	< 1	mg/L
Free chlorine gas (Cl ₂)	< 0.5	mg/L
Nitrate (NO ₃ ⁻)	< 100	mg/L
Ammonia (NH ₃)	Not permitted	---
Iron (Fe), dissolved	< 0.2	mg/L
Manganese (Mn), dissolved	< 0.05	mg/L
Aluminum (Al), dissolved	< 0.2	mg/L
Free aggressive carbon dioxide (CO ₂)	Not permitted	---
Hydrogen sulfide (H ₂ S)	Not permitted	---
Algae growth	Not permitted	---
Suspended matter	Not permitted	---

5 Commissioning

5.1 Establishing a mains connection



DANGER! Transport damage

Electric shock

- Closely inspect the device for transport damage prior to starting up.
- Never operate a device that has sustained transport damage!



DANGER! Contact with voltage conductors due to faulty power supply cable

Electric shock

- The power supply cable must not come into contact with hoses containing heat transfer liquid or other hot parts.



DANGER! Formation of condensation (after transport)

Electric shock

- After transporting the device, wait for at least 24 hours, before putting it into operation to allow the device to adapt to the temperature at the installation location.



NOTICE! Use of impermissible mains voltage or mains frequency

Device damage

- Compare the type plate with the available mains voltage and mains frequency.



NOTICE! Bath unit type incorrectly set in the software and control cable not connected

Device damage

- When replacing the bath unit, always set the correct type in the device menu, see [Chapter 6.4 “\[BATH TYPE\] – Selecting the bath unit”](#) on page 55
- On cold baths, always connect both power supply and control cables to the pump and control unit.

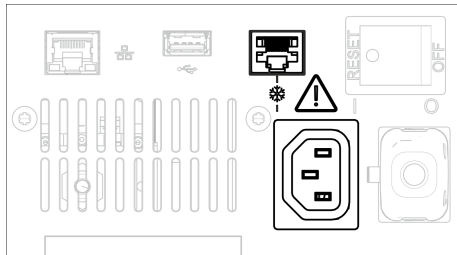

Fig. 15: Sockets for connecting the cold bath cables

Note on the power supply for cooling thermostats:

- Before connecting a device to the mains power, always compare the mains voltage and mains frequency with the type plate on the pump and control unit and with the type plate on the cold bath. If the specifications for the mains voltage range of the pump and control unit and the cold bath are different, the overlapping range applies. The mains voltage and frequency must be within this range.
- The pump and control unit supplies power to the cold bath. Connect both cables for the cold bath's control and power supply to the pump and control unit. A snowflake symbol on the rear of the pump and control unit indicates the corresponding sockets.

Note for electric installation on site:

- The devices must be protected by a circuit breaker with a rated current not exceeding 16 amps.
 - Exception: For devices with a UK plug, the rated current is limited to a maximum of 13 amps.
- For information about the device's maximum current consumption, refer to the type plate of the pump and control unit.

Please note:

- The mains plug on the device is the primary component for disconnecting from the power supply. The mains switch (circuit breaker) on the device only has a safety function.
 - The mains plug must be easy to identify.
 - The mains plug must be easy to access.
 - It must be easy to pull the mains plug out of the socket.
- Always use standard power supply cables such as the one supplied.
- Connect the device to a socket with a protective earth conductor (PE).

5.2 Display and navigation

Home window

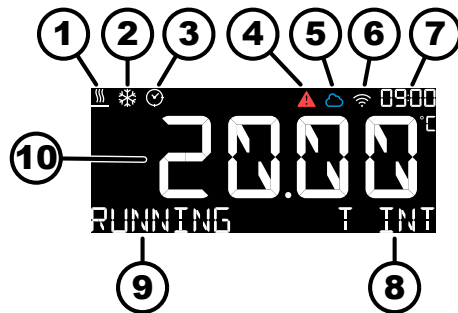

Fig. 16: Home window

After the device has been switched on, the home window with the [T INT] menu item is always displayed for the current internal bath temperature.

Depending on the operating status, the following information is displayed:

- 1 Heating is active
- 2 Cooling is active
- 3 Timer symbol
- 4 Alarm symbol; an alarm has been triggered or there is an error
- 5 Cloud connectivity symbol
- 6 WLAN connectivity symbol (on devices with WLAN function)
- 7 Current time
- 8 Current menu item
- 9 Operating status (only displayed for [T INT] menu item)
- 10 Value of the current menu item



In the event of an error message, the alarm symbol is displayed in the home window and an acoustic signal sounds. The acoustic signal is muted if a button is pressed. If an alarm is active or there is an error message, the display automatically switches to the [NOTIFICATIONS] menu item.

Navigating through the device menu

- The current menu item is displayed on the bottom right-hand side of the display ⑧.
- The [T INT] menu item is displayed for the actual internal bath temperature.
- From the home window, press the [up arrow key] to access other menu items. Use the [Enter key] to select values to make settings or to open sub-menus.
A sub-menu is displayed in the large display line ⑩ as [MENU].
- To make settings, press the [Enter key] (display flashes), change the setting with the [arrow keys] and confirm the change with the [Enter key].
- If the change is not confirmed with the [Enter key] within 8 seconds, it will be automatically rejected and the original value will be retained.
- Press the [up arrow key] to move up one menu level from the first menu item in a sub-menu until you reach the home window displaying the internal bath temperature [T INT].
- 20 seconds after changing and confirming a setting or without changing a setting, the display automatically changes to the [T INT] home window.



Menu structure

You can find the complete menu structure in ↗ Chapter 5.3 “Menu structure” on page 44.

5.3 Menu structure

Level 1	Level 2	Level 3
T INT		
T SET		
T IH		
T IL		
COOL MODE **		
SHUTDOWN TIMER		
	TIMER HOURS	
	TIMER MINUTES	
BATH TYPE		
NETWORK	LAN	IP
		MASK
		GATE
		DNS
		MAC
	WLAN *	ACTIVATE WLAN
		START WPS CONNECT
		START PSK CONNECT
	PC CONTROL	ALLOW PC CONTROL
		PORT
		INTERFACE TIMEOUT
	WEBSERVER	ALLOW WEBSERVER
		DEL. ACCESS AUTH
	LAUDA.LIVE	ON/OFF
OP.PRM.READABLE		
OP.PRM.WRITABLE		
SVC.PRM.READABLE		
SVC.PRM.WRITABLE		
INFO	DATE AND TIME	TIME ZONE
		HOUR
		MINUTE
		YEAR
		MONTH
		DAY
	START UPDATE	
	SW VERSION	CONTROL SYSTEM
		WEBAPI
WEB		
	SNR	
	TEMP.GRAPH	
NOTIFICATONS		
CALIBRATION	CALIBRATION VALUE	
	CALIBRATION RESET	
RESTORE FAC. SET.		

Fig. 17: Universa ECO menu structure

* In countries that do not currently have WLAN approval, device variants without an integrated WLAN function are available.

** Only for cooling thermostats

The following chapter describes the basic settings for the set temperature [T SET] and the [T IH] and [T IL] temperature limits. The other menu items are described from Chapter 6 “Operation” on page 49 onwards.

5.4 Basic settings for commissioning

WARNING!
Device is started using a remote control

Scalding, slipping, environmental hazard

- Do not switch on the device at the mains switch until all hydraulic connections for the application have been fully established and all measures for safe commissioning have been implemented.

The basic settings must be configured on the device in the following cases:

- At initial start-up
- At every start-up
- Every time the heat transfer liquid is changed.

You may only fill the device after having configured the settings as described in the following chapters.

5.4.1 Sequence and limitation of inputs

The following diagram illustrates the input limits.

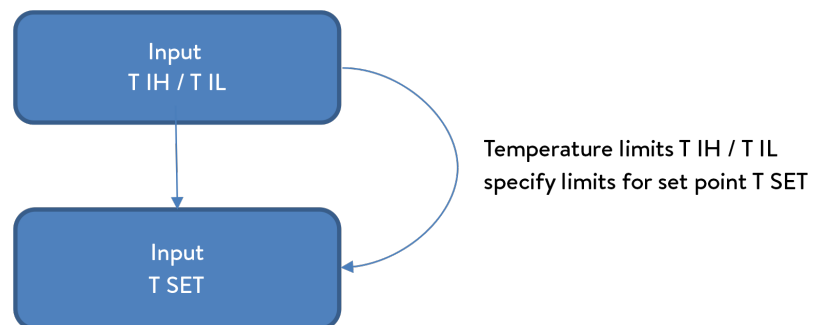

5.4.2 Setting the temperature limits

There are two temperature limits:

T IH - upper limit (Temperature Internal High)

T IL - lower limit (Temperature Internal Low)

This function is used to set the T_{IH} and T_{IL} temperature limits. The temperature limits restrict the temperature set point. If the actual internal temperature T_{INT} is outside the temperature limits, a warning is issued and the heating is switched off. The temperature limits should reflect the limits of your application. A tolerance of 2 K should also be added to the upper and lower temperature limits to compensate for overshooting in the controls. The difference between the two temperature limits must be at least 10 K. The configurable range of both limits also depends on the bath unit used and set in the device menu.

The working temperature range of the heat transfer liquid must also be taken into consideration when defining the temperature limits.



Fig. 18: Setting the upper limit



Fig. 19: Setting the lower limit

1. Press the [up arrow key] until the T_{IH} menu item is displayed.
2. Press the [Enter key].
 - ▶ The currently set limit value flashes in the display.
3. Change the value with the arrow keys.
4. Press the [Enter key].
 - ▶ The new value has been accepted.
5. Press the [down arrow key] until the T_{IL} menu item is displayed, and repeat steps 2 to 4 to set the lower limit.

5.4.3 Setting the set temperature



Fig. 20: Setting the set temperature

Personnel: Operating personnel

1. Press the [down arrow key] until *TSET* is displayed in the menu item.
2. Press the [Enter key].
 - ▶ The currently set temperature flashes in the temperature display.
3. Press the arrow keys to change the set temperature.
4. Press the [Enter key].
 - ▶ The new value has been accepted.



- *The temperature can only be set within the temperature range permitted for the device.*
- *Any values outside this range are not accepted.*

5.5 Filling the device

LAUDA is not liable for damages resulting from the use of unsuitable heat transfer liquids. Approved heat transfer liquids ↪ Chapter 4.4 “LAUDA heat transfer liquids” on page 38.



DANGER!
Spraying of heat transfer liquid

Electric shock

- Do not spray heat transfer liquid.



WARNING!
Splashing heat transfer liquid

Eye damage

- Always wear suitable safety glasses when working on the device.



CAUTION!
Overflow of heat transfer liquid

Slipping or falling over

- Do not overfill the device.



CAUTION!
Leaking heat transfer liquid

Slipping or falling over

- Drain tap must be closed.
- Ensure that all hydraulic connections are tight.



Heat transfer liquids expand when heated (approx. 10% for every 100°C). If an external consuming unit is connected, expansion occurs exclusively in the thermostat bath.

Bath thermostat

1. Close the drain valve by turning it clockwise.
2. Carefully fill the bath with heat transfer liquid.



The recommended fill level in the bath thermostat is between 30 and 40 mm below the upper edge of the bath.

The heating, pump housing and return connector must be covered with liquid.

6 Operation

6.1 Safety instructions prior to operation

All work on the device

	<p>CAUTION! Danger due to inaccessible mains switch</p>
	<p>Scalding, cold burns</p>
	<ul style="list-style-type: none"> ● Make sure that the mains plug is always easily accessible. It must be possible to quickly pull the mains plug out of the socket.

	<p>DANGER! Risk of immersion thermostat falling into the bath</p>
	<p>Electric shock</p>
	<ul style="list-style-type: none"> ● Only operate immersion thermostats on circuits with a residual current device (RCD). ● Make sure that the immersion thermostat bracket is securely connected to the bath. ● Only use bath vessels that are stable enough to support the immersion thermostat and designed to withstand the intended operating temperatures.

	<p>DANGER! If the pump and control unit are positioned incorrectly on the bath, vapors will cause deposits to form on printed circuit boards.</p>
	<p>Electric shock</p>
	<ul style="list-style-type: none"> ● If vapors are generated above the heat transfer liquid, use a sealed cover on the bath, wherever possible. Vapors must be prevented from entering the pump and control unit.

The following safety warning is valid for mains cables with a socket (for non-heating apparatuses) in accordance with IEC-60320 without a locking function on the pump and control unit:

	<p>DANGER! The power supply cable with a socket (for non-heating apparatuses) without a locking function detaches itself from the connection socket on the pump and control unit.</p>
	<p>Electric shock</p>
	<ul style="list-style-type: none"> ● Make sure that the mains cable cannot fall into the bath.



DANGER!

If the pump and control unit are positioned incorrectly on the bath, the power supply cable will be exposed to high temperatures. Contact with live cables.

Electric shock

- Immersion of the power supply cable in the heat transfer liquid and contact between the power supply cable and hot surfaces (> 70 °C) must be avoided.



WARNING!

Splashing heat transfer liquid

Eye damage

- Always wear suitable safety glasses when working on the device.



WARNING!

Risk of mechanical damage to refrigerant circuit

Burns, fire

- Do not use mechanical tools to accelerate de-icing.



WARNING!

Risk of cooling circuit bursting due to excessive gage pressure

Burns, fire

- Ensure that none of the ventilation grids on the fan of the constant temperature equipment are blocked, including the front air inlet of the cold bath and the air outlets.



WARNING!

Leaks in the cooling circuit

Burns, fire

- Do not use corrosive heat transfer liquids.



WARNING!
Operating errors, technical defect

Fire

- Disconnect the mains plug to safely disconnect from the mains power.



CAUTION!
Unauthorized control

Scalding, cold burns

- Always operate the process interface in a protected intranet (firewall).



CAUTION!
Object falling into the bath splashes heat transfer liquid

Scalding, cold burns

- Do not place any objects on the pump and control unit.



CAUTION!
Competing settings due to simultaneous operation on the device and via LAUDA.LIVE

Scalding, cold burns

- If the user allows cloud access for write commands, conflicting settings may occur (cloud, operator terminal).



CAUTION!
Risk of heat transfer liquid leaking from incorrectly sealed pump connections

Scalding, cold burns

- Attach a pump link to the pump connections if an external consuming unit is not connected.



CAUTION!
Contact with hot/cold surfaces

Hot and cold burns

- Never touch parts that are labeled with the warning symbol "Hot surface".



CAUTION!
Restrictions during operation or setup

Ergonomic impairment

- Position the LAUDA thermostat on a table, pedestal or the floor so that all operating elements are easy to use (bath, connections, interfaces, display, keyboard).
- Devices with 4 castors are only suitable for positioning on the ground so that they are prevented from falling from an elevated height.



CAUTION!
Contact with heat transfer liquid vapors

Breathing difficulties

- Use an extractor system.
- Use a bath cover wherever possible.



NOTICE!
Water damage caused by use of the cooling coil

Damage to the facility

- To avoid water damage caused by leaks from the cooling water system, use a leakage water detector with water shut-off function.

6.2 [COOL MODE] – Cooling unit operating mode

The cooling unit of the devices is operated in the [AUTO] standard setting. Depending on the temperature and operating status, the cooling unit is switched on or off automatically (recommended mode of operation). You can switch the cooling unit on or off permanently via the menu. In the case of sensitive control processes, control fluctuations can be prevented by automatically switching the cooling unit on or off. When the [OFF] setting is selected, only temperatures above room temperature can be reached. Selecting the [ON] setting may result in increased energy consumption due to permanent operation of the cooling unit.



Fig. 21: Selecting operating modes

1. Select the *COOL MODE* menu item and press the [Enter key].
2. The display flashes and you can use the arrow keys to choose between the following operating modes:
 - [AUTO] - The cooling unit is switched on and off automatically as required.
 - [OFF] - The cooling unit remains permanently switched off.
 - [ON] - The cooling unit remains permanently switched on.
3. Confirm the selection with the [Enter key].

6.3 [SHUTDOWN TIMER] – Using the shutdown timer

A shutdown timer can be set and started in the [SHUTDOWN TIMER] menu item. After the set time has expired, the device changes from the operating status [RUNNING] to [STOPPED]. This switches off the pump, the heating and, on cooling thermostats, also the cooling unit.

Setting the timer

A maximum shutdown time of 99:59 (HH:MM) can be set.

1. Select the menu item
SHUTDOWN TIMER → *TIMER HOURS*
 - ▶ The timer's currently set number of hours is displayed.
2. Press the [Enter key], use the arrow keys to select the number of hours and confirm with the [Enter key].
3. In the menu item
SHUTDOWN TIMER → *TIMER MINUTES*, repeat the setting for the number of minutes.



Fig. 22: Timer set to one hour

Starting the timer

1. Select the menu item
SHUTDOWN TIMER → *TIMER CONTROL*.
2. Press the [Enter key], use the arrow keys to select *START*, and confirm with the [Enter key].



The timer also starts if the device is already in the [STOPPED] operating status.

- ▶ The timer starts and the timer symbol is displayed.



Fig. 23: Timer started



Fig. 24: Remaining time on timer

- ▶ In the menu item *SHUTDOWN TIMER*, the timer's currently remaining time (HH:MM) is displayed.



Fig. 25: Timer's remaining seconds

- ▶ When the hours and minutes expire, the remaining number of seconds is indicated instead.



Fig. 26: Home window when timer expires

- ▶ When the timer expires and the device has stopped, the timer symbol flashes until a button is pressed.
- ▶ In the menu item [*SHUTDOWN TIMER*], [*OFF*] is displayed and the previously set hours and minutes of the shutdown timer are reset to 0.



Before restarting the timer, the minutes and hours must be reset.

Stopping the timer

1. Select the menu item
SHUTDOWN TIMER → *TIMER CONTROL* → *START*
2. Press the [Enter key], use the arrow keys to select *STOP*, and confirm with the [Enter key].
 - ▶ The timer stops and the timer symbol is hidden in the display.
 - ▶ In the menu item [*SHUTDOWN TIMER*], [*OFF*] is displayed and the previously set hours and minutes of the shutdown timer are reset to 0.

6.4 [BATH TYPE] – Selecting the bath unit



The bath unit operates the pump and control unit as a heating and cooling thermostat and must be adjusted if the system configuration is modified.

1. Select the *BATH TYPE* menu item.
 - ▶ The currently set bath unit is displayed.
2. Press the [Enter key]. The setting flashes; use the arrow keys to select the correct bath unit. Select the bath unit according to the type information on the bath unit type plate.
3. Confirm the selection with the [Enter key].
 - ▶ The new setting is active.



Incorrect configuration

If a cold bath is configured incorrectly, the error message E056 is issued.

6.5 [NETWORK] – Network, web server and cloud

In the [NETWORK] menu item, you can carry out configurations for connections to networks, to the web server and to the cloud LAUDA.LIVE.

- [LAN] - You can view the configuration for the network interface here. The network settings can only be obtained automatically. The requirement for this is that a DHCP server must be present in the local network (LAN). If communication is direct, the PC of the external control unit must support the auto IP procedure.
The network settings cannot be carried out manually with a fixed IP address.
- [WLAN] - The WLAN menu is only displayed on factory-fitted WLAN modules:
Settings to connect the device to a wireless network (WLAN).
In the same way as for a connection to a LAN, the network settings for the WLAN connection can only be obtained automatically.
- [PC CONTROL] - Configure remote access to the device via the Namur interface.
- [WEB-SERVER] - Configure access to the device via the LAUDA Command app or a web browser.
- [LAUDA LIVE] - Configure connection to LAUDA.LIVE cloud.

6.5.1 View LAN configuration

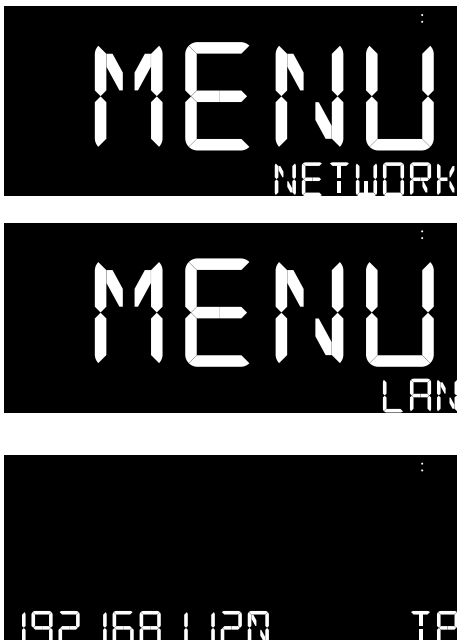



Fig. 27: IP address display

You can view the configuration assigned by a DHCP server as follows:

1. Select the *NETWORK* → *LAN* menu item and press the [Enter key] to access the [LAN] submenu.
2. In the [LAN] menu, the following parameters for the LAN configuration and the MAC address of the network interface can be viewed:
 - [IP] - IP address assigned by the DHCP server
 - [MASK] - Local mask
 - [GATE] - Gateway
 - [DNS] - DNS server
 - [MAC] - MAC address

6.5.2 Connecting the device to a wireless network (WLAN)

The WLAN menu and the WLAN symbol are only visible if the constant temperature equipment supports the WLAN function.

The WLAN symbol  can be found in the status bar in the top part of the display. The symbol indicates the following statuses:

- Symbol off - WLAN function not activated or not integrated into the device
- Symbol flashes - WLAN function is activated but there is no connection
- Symbol rotates - Establishing a WLAN connection
- Symbol lights up continuously - WLAN connection active.
For an existing connection, the number of bars indicates the quality of the connection.

In some countries, the LAUDA Universa thermostats support connection to a wireless network.

WLAN-capable devices are only available for purchase in the following regions:

- European Union
- United Kingdom
- Switzerland
- USA
- Canada
- India

For an updated list, please download the operating instructions from the LAUDA website. The version available for download always contains an updated list of countries in which WLAN-capable device variants are available. WLAN-capable devices may only be operated in the countries listed above. In countries that do not currently have WLAN approval, device variants without an integrated WLAN function are available. If necessary, contact your sales partner for further information.



The device can only connect to wireless networks in the 2.4 GHz band according to IEEE 802.11 b/g/n. The device supports WPA, WPA2 and WPA3 encryption to protect data transmission. When establishing a connection, the device adopts the encryption method and the connection parameters of your access point.

You can connect the device to a wireless network using various login mechanisms. Choose the method that is compatible with your existing infrastructure.

- WPS procedure (WiFi Protected Setup)
- WPA-PSK (WiFi Protected Access with Pre-Shared Key)

Activating WLAN

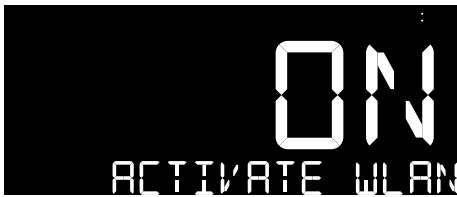
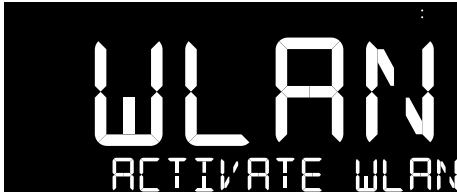

Before establishing a connection, the WLAN function must first be activated, if necessary.

1. Select the menu items
NETWORK → *WLAN* → *ACTIVATE WLAN*.
2. In [ACTIVATE WLAN], select the [ON] option and confirm with the [Enter key].
 - ▶ The function is activated and the WLAN symbol is displayed in the symbol bar in the top part of the display. The symbol flashes for as long as there is no WLAN connection.

Connection using the WPS procedure



In order to establish a connection using the WPS method, your access point must support WPS.

1. Select the menu items
NETWORK → *WLAN* → *START WPS CONNECT*
and press the [Enter key].
2. Press the WPS key at your access point.
3. At the access point, check whether the connection has been established. This can take up to two minutes, depending on the access point.
4. Check whether the WLAN symbol  at the top of the display is continuously displayed.
 - ▶ The connection has been established.

Connection with pre-shared key (WPA-PSK)

Authentication with a pre-shared key is the most widely used method. The device is integrated into an existing network by disclosing the common network key. The login information, the WLAN name and the WLAN password for your network is transferred to the device via a USB stick.



Restriction to FAT32 formatting on USB sticks

When using a USB stick in a USB socket host (type A) on the constant temperature equipment (e.g. for the software update) or the interface module, it must be formatted with FAT32. USB sticks (> 32 gigabytes) are generally factory-formatted with exFAT and therefore do not work with the constant temperature equipment. Use a USB stick with max. 32 gigabytes so that formatting is possible.

Proceed as follows:

1. Download the text file with the name **pskCfg.txt** (UTF8 format) from the LAUDA website.
<https://www.lauda.de/de/services/download-center/filter/Installationsanleitung/Universa>
2. Open the file with Windows text editor. Enter the name of your WLAN in SSID. Enter the password in Password.
3. Save the file onto a USB stick and insert it into your LAUDA constant temperature equipment.
4. Select the menu items
NETWORK → *WLAN* → *START PSK CONNECT*
and press the [Enter key].
5. Wait up to two minutes for the connection to be established.
6. Check whether the WLAN symbol  at the top of the display is continuously displayed.
 - ▶ The connection has been established.



SAR limits



This device with integral WLAN module complies with the SAR limits for a controlled environment. The normal distance to the device is 20 cm or more. A distance of less than 20 cm must not be permanently maintained.

6.5.3 [PC Control]– Operating the device using the Ethernet interface

To operate the equipment via an external control unit (control station, PC), the constant temperature equipment can be connected via the standard Ethernet interface.

To enable access to the device via the interface, this must be set in the device software beforehand.

Enabling access via the Ethernet interface



1. Select the menu items
NETWORK → *PC CONTROL* → *ALLOW PC CONTROL*
and press the [Enter key].



Fig. 28: Approving access to the interface

Connection monitoring

2. In [ALLOW PC CONTROL], select the [ON] setting and confirm with the [Enter key].
 - ▶ Access to the device via the interface is approved.

On delivery, connection via the Ethernet interface is not actively monitored. A threshold for a timeout from one to 600 seconds can be set. If a command is not sent to the device via the interface for a period exceeding the set threshold, the constant temperature equipment triggers alarm 22 (↪ Table 26 “Alarms” on page 83).

Every new command within the set threshold resets the timeout for triggering the alarm specified by the threshold.

A threshold of 0 must be set to deactivate monitoring of the connection.

You can specify the threshold for the timeout in the device menu or using interface command [OUT_SP_08_XX]. This must be carried out before the start of communication.

Specification in the device menu



Fig. 29: Connection monitoring deactivated

1. Select the menu items *PC CONTROL* → *INTERFACE TIMEOUT* and press the [Enter key]



Fig. 30: Example: threshold 60 seconds

2. The set threshold flashes. Use the arrow keys to set the required value and press the [Enter key] to confirm.
 - ▶ The new threshold is active after the connection has been established.

6.5.4 Protocol of the interface

Note the following instructions:

- The command from the computer must be made with a CR, CRLF, or LFCR.
- The response from the thermostatic circulator is always made with a CRLF.
- After each command sent to the thermostat, it is necessary to wait for the reply before sending another command. This ensures that the sequencing of inquiries and answers is clear.
CR = Carriage Return (Hex: 0D); LF = Line Feed (Hex: 0A)

Table 12: Example with set point transfer of 30.5 °C to the thermostatic circulator

Computer	Temperature control device
"OUT_SP_00_30.5" CRLF	→
←	"OK" CRLF

6.5.5 Read commands of the interface

The interface recognizes the following read commands, which you can use to retrieve the operating data of the constant temperature equipment.

Table 13: Temperature

ID	Function	Unit, resolution	Command
2	Set temperature T SET	[°C]	IN_SP_00
3	Bath temperature T INT	[°C], 0.01 °C	IN_PV_00

ID	Function	Unit, resolution	Command
27	Upper temperature limit T IH	[°C]	IN_SP_04
29	Lower temperature limit T IL	[°C]	IN_SP_05

Table 14: Set value

ID	Function	Unit, resolution	Command
11	Resolution of controller actuating signal in per mill – negative value → device is cooling – positive value → device is heating	[%]	IN_PV_06
13	Controller actuating signal in watts – negative value → device is cooling – positive value → device is heating	[W]	IN_PV_08

Table 15: Cooling

ID	Function	Unit	Command
24	Cooling mode: 0 = Off / 1 = On / 2 = Automatic	[-]	IN_SP_02

Table 16: Safety

ID	Function	Unit	Command
35	Timeout communication via interface (1 - 600 seconds; 0 = Off)	[s]	IN_SP_08
202	Status of exclusive operator privileges for the interface (1 = Active/ 0 = Inactive)	[-]	IN_MODE_09

Table 17: Status

ID	Function	Unit	Command
75	Standby status: 0 = device is on / 1 = device is off	[-]	IN_MODE_02
107	Product line / equipment series: ■ UNI (= Universa)	[-]	TYPE
130	Device status: 0 = OK / -1 = fault	[-]	STATUS

ID	Function	Unit	Command
131	Fault diagnosis bits 0 = inactive, 1 = active; <ul style="list-style-type: none"> ■ Bit 0 = collective error ■ Bit 1 = collective alarm ■ Bit 2 = collective warning ■ Bit 3 = overtemperature ■ Bit 4 = low level ■ Bit 5 = high level ■ Bit 6 = external control value missing 	[-]	STAT
161	Serial number, alphanumerical (10 characters)	[-]	SERIAL_NO

Table 18: SW version

ID	Function	Unit	Command
108	Control system	[-]	VERSION_R

6.5.6 Write commands of the interface

The interface recognizes the following write commands, which you can use to transfer values to the constant temperature equipment.

Table 19: Temperature

ID	Function	Unit	Command
1	Set temperature T SET	[°C]	OUT_SP_00_XXX.XX
26	Upper temperature limit T IH	[°C]	OUT_SP_04_XXX.XX
28	Lower temperature limit T IL	[°C]	OUT_SP_05_XXX.XX

Table 20: Cooling

ID	Function	Unit	Command
23	Cooling mode: 0 = Off / 1 = On / 2 = Automatic	[-]	OUT_SP_02_X

Table 21: Safety

ID	Function	Unit	Command
34	Timeout communication via interface (1–600 seconds; 0 = Off)	[s]	OUT_SP_08_XXX
201	Activate/deactivate exclusive operating privileges for interface 1 = obtain exclusive privileges. 0 = Relinquish exclusive privileges	[-]	OUT_MODE_09_X

Table 22: Status

ID	Function	Unit	Command
74	Switch the device on / off (standby): 0 = switch on / 1 = switch off	[-]	START / STOP

6.5.7 Web server LAUDA Command

The embedded Web server

The LAUDA device is equipped with an integrated Web server. The web server is used to visualize process-related data inside the device, such as temperature, pressure and flow rate. The scope of the information displayed depends on the device, device type and installed accessories.

You can use the following software to access the web server:

- LAUDA Command app:
Available in the app stores for mobile devices based on iOS and Android and in the Windows Store for Windows-based PC systems.
The LAUDA Command app can also be downloaded from the LAUDA homepage for Windows-based PC systems. Open the LAUDA homepage, tap → *Services* → *Download center*. In the Download center, chose the [Software] option in the [Document type] drop-down list.
- Web browser:
Connection to the LAUDA device via a browser.

Requirements

- The LAUDA device and the PC/control station must be connected to the same network. The network settings must be obtained automatically via DHCP. It is not possible to set a fixed IP address, see also ↪ Chapter 6.5 “[NETWORK] – Network, web server and cloud” on page 55.

Enabling access to the web server



1. Select the menu items *NETWORK* → *WEBSERVER* → *ALLOW WEBSERVER* and press the [Enter key].
2. In [ALLOW WEBSERVER], select the [ON] setting and confirm with the [Enter key].
 - ▶ Access to the web server is approved.

Fig. 31: Approving access to the interface



Connection to the device via the LAUDA Command App

LAUDA recommends using the LAUDA Command app. If you use this app, state-of-the-art security mechanisms which offer a very high level of security against digital threats are automatically put in place. In addition to this, the App has an integrated search service for LAUDA devices in the local network, so that manual entry of a host name or IP address is no longer necessary.

Table of protocols used in the ISO/OSI model

Layers	Protocols
7 Application	HTTPs, DNS, DHCP server, Auto-IP, TLS, mDNS
6 Presentation	
5 Session	
4 Transport	TCP, UDP
3 Network	IP
2 Data link	Physical network
1 Physical layer	

Operating the device with the app

You are using the LAUDA Command app. This automatically searches for existing devices in the network. The devices found are displayed in a list. Select the required device. Connection to the device is established. If a connection to a device was established before closing the App, connection to this device is established when the App is started again.

Security with the web browser

The LAUDA device can be accessed with a web browser if users cannot use the LAUDA Command app for technical reasons or their IT guidelines prohibit this.

You must install the LAUDA CA certificates (Root CA, Device CA) to obtain a high level of security when using a web browser.

You must carry out the following before using a web browser:

1. Download the CA certificates from the LAUDA homepage before connecting for the first time.
Open the LAUDA homepage, tap → *Services* → *Download center*.
2. In the Download center, chose the [Certificate] option in the [Document type] drop-down list.
 - ▶ A list of the certificates appears.
3. Tap the relevant certificate.
 - ▶ The download starts and a zip file is downloaded.
4. Install the certificates on all end devices which will be used later to access the LAUDA device.
5. Confirm the prompt inquiring whether you trust the LAUDA certificates with [Yes].
6. Confirm the connection.

Operating the device via the Web server

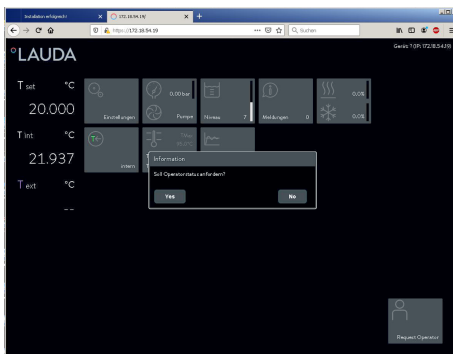

Fig. 32: Web server in the browser window

Operation of the LAUDA devices via the web server is carried out in the same way as operation via the operating unit on the device. If required, please refer to the respective descriptions of operation provided in this operating manual.

Operation of the device via the LAUDA Command App is very similar to the Command Touch remote control, the operating instructions of which can be downloaded from our homepage. Open the LAUDA homepage, tap → *Services* → *Download center*. In the Download center, chose the [PRO] option in the [Product line] drop-down list.

You need the IP address or the serial number of the constant temperature equipment when you use the web browser. Enter the IP address or the serial number in the address line of the browser. Connection to the device is established.

Viewing the IP address

Select the *NETWORK* → *LAN* → *IP* menu item in order to view the IP address assigned to the device by the DHCP server.

Viewing the serial number

Select the *INFO* → *SNR* menu item to view the device's serial number.

Cookies

Cookies must be activated if you use a web browser. The device creates a cookie with a connection-specific token which is generated during the initial mutual authentication. This information is lost if the cookie is rejected or deleted. Authentication must then be repeated the next time a connection is established.

Contact your network administrator if you require further assistance in implementing secure access.

Two-Factor Authentication (2FA) for increased security

Two-Factor Authentication is an authentication using a combination of two different and independent paths. The user is checked by the remote station and the remote station is checked by the user.

In the case of LAUDA, a user with automatically generated access data is created in the constant temperature equipment during the 2FA. The access data is stored in the App in the form of a token and as a cookie in the web browser. The token is valid for 6 months. In addition to this, all registered users (tokens) can be deleted via the Master on the constant temperature equipment, see [🔗](#) “Deleting two-factor authentication (2FA) for all registered users” on page 67. The user must repeat the 2FA in these cases.

The 2FA must be performed:

- At the first connection.
- When the token is no longer valid.
- When the cookie is no longer valid.
- If the cookie has been deleted in the browser or has not been saved.

The user is automatically prompted by the App or the web browser if a 2FA is necessary. A 6-digit one-time password is shown on the display of the device during 2FA. This is valid for 5 minutes.

Type the code displayed in the Web client and confirm your entry. The connection is continued if authentication is successful. If an error occurs, check whether your entry was correct.



Limited character set

Please note that due to the segment display, only uppercase letters A–Z are used in the displayed one-time password.

Deleting two-factor authentication (2FA) for all registered users



1. Select the menu items `NETWORK → WEBSERVER → DEL. ACCESS AUTH.` and press the [Enter key].
2. Select [YES] and press the [Enter key] to confirm.
 - ▶ 2FA deleted for all registered users.

Fig. 33: Delete authentication

6.5.8 LAUDA.LIVE cloud service

The LAUDA Universa enables the communication of device data to the cloud-based service LAUDA.LIVE. The service provides various optional features and offers, such as remote maintenance.

Please contact LAUDA or visit our website for detailed information about LAUDA.LIVE and its services.

To implement the LAUDA.LIVE service, device data is exchanged with the LAUDA.LIVE cloud via an encrypted connection, enabling the LAUDA service to remotely maintain the constant temperature equipment.



LAUDA.LIVE access and data transmission are disabled by default.

Allowing access to the LAUDA.LIVE cloud



1. Select the *NETWORK* → *LAUDA.LIVE* menu item and press the [Enter key].
 - ▶ The current setting flashes in the display. Before leaving the factory, access to the cloud is deactivated with [OFF].
2. Select the [ON] setting and press the [Enter key] to confirm.
 - ▶ Access to the cloud is activated. If a connection exists, the cloud symbol is displayed.

Fig. 34: Approve access to the cloud

After switching on, the constant temperature equipment is registered and authenticated via an encrypted TLS connection and using a device-specific X.509 certificate in LAUDA.LIVE. For security reasons, the connection can only be initiated by the constant temperature equipment. The status of the connection to LAUDA.LIVE is displayed under the *NETWORK* → *LAUDA.LIVE* → *STATE* menu items:

- OK - currently connected to LAUDA.LIVE
- CONN. - connecting to LAUDA.LIVE
- OFF - LAUDA.LIVE switched off

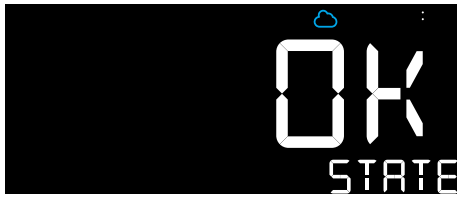

Fig. 35: Existing connection, cloud symbol in the status bar

Configuring LAUDA.LIVE access



Fig. 36: Approval of reading of operating parameters

If a connection to LAUDA.LIVE already exists, a cloud symbol also appears in the status bar of the home window.

Since LAUDA provides the user with full control over the data to be transferred, device data is not transferred until LAUDA.LIVE access has been configured.

1. In the *NETWORK* → *LAUDA.LIVE* menu, you can access the device data under the following menu items.

[OP. PRM. READABLE] - Read operating parameters

[OP. PRM. WRITABLE] - Write operating parameters

[SVC. PRM. READABLE] - Read service parameters

[SVC. PRM. WRITABLE] - Write service parameters

A distinction is made between the operating parameters (such as configured set point or internal bath temperature) and the service parameters. The operating parameters are parameters that are displayed on the device display for the user and can be modified by the user. In contrast, the service parameters are only available to the LAUDA Service.



The reading of parameters in the constant temperature equipment from the cloud is activated on the device side via the [OP. PRM. READABLE] and/or [SVC. PRM. READABLE] menu items.



Changing parameters in the constant temperature equipment from the cloud, e.g. as part of remote maintenance by the LAUDA service, is activated on the device side via [OP. PRM. WRITABLE] and/or [SVC. PRM. WRITABLE].

2. Select the required access option and press the [Enter key] to directly change the setting.
 - ▶ You can approve access with [ON] or lock access with [OFF].

In addition to measures provided in LAUDA.LIVE for authorizing access and changing device data, e.g. two-factor authentication, the device-side access configuration is used by the user for basic restriction/control of the LAUDA.LIVE services.

6.6 [INFO] – Further settings, information and software update

In the [INFO] menu item, you can make the following settings and carry out the following functions:

- Set the date and time
- Carry out a device software update
- View software versions and serial numbers

6.6.1 Set the date and time

In the *INFO* → *DATE AND TIME* menu item, you can select the time zone and set the date and time.



As long as the device is connected to the Internet, the time will be updated automatically. In this case, the time zone must be set correctly.

Selecting the time zone



1. Select the menu item *INFO* → *DATE AND TIME* → *TIMEZONE* and press the [Enter key].



2. Select the time zone with the arrow keys and press the [Enter key] to confirm.
 - ▶ The time zone is selected.



Set the date and time

In the *INFO* → *DATE AND TIME* menu item, you can set the date and time with the following menu item:

[HOUR] - Hours
[MINUTE] - Minutes
[YEAR] - Year
[MONTH] - Month
[DAY] - Day

1. Select the required date or time information in the menu, and press the [Enter key].
2. The display flashes and you can set the information using the arrow keys.
3. Press the [Enter key] to confirm the setting.

6.6.2 Carrying out the software update

If you wish to install updated device software on the device, carry out the software update as follows:

1. Copy the firmware data (.fwu) provided by LAUDA onto an empty USB stick.



Restriction to FAT32 formatting on USB sticks

When using a USB stick in a USB socket host (type A) on the constant temperature equipment (e.g. for the software update) or the interface module, it must be formatted with FAT32. USB sticks (> 32 gigabytes) are generally factory-formatted with exFAT and therefore do not work with the constant temperature equipment. Use a USB stick with max. 32 gigabytes so that formatting is possible.

2. Switch on the device.



Make sure that the date and time on the device are set correctly. This is important for verifying the digital signature of the firmware file.

3. Insert the USB stick into the USB interface on the back of the pump and control unit, see Fig. 3.
4. Select the *INFO* → *START UPDATE* menu item and press the [Enter key].



5. Select the [YES] option and press the [Enter key] to confirm.
 - ▶ The software update is carried out.
6. Wait until the software update has finished. Then switch off the device at the mains switch.
7. Remove the USB stick.
8. Switch the device back on one minute at the earliest after switching it off.
 - ▶ The software update has been successfully carried out.

6.6.3 View software versions and serial numbers

Software versions



1. Select the *INFO* → *SW VERSION* menu item and press the [Enter key] to access the submenu.



2. The device software is displayed with the *CONTROL SYSTEM* menu item.
More serial numbers, e.g. from the web server, can be viewed using the arrow keys.

Serial numbers

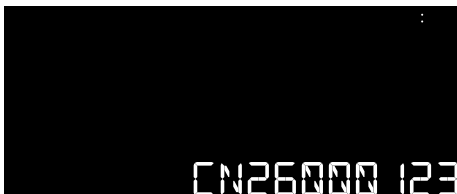

1. Select the *INFO* → *SNR* menu item and press the [Enter key].
2. The device's serial number is displayed in the bottom display line.

6.7 [NOTIFICATIONS] – Displaying error messages

All active messages can be viewed in the [NOTIFICATIONS] menu item.



A list of error messages with descriptions and possible remedies can be found in ↪ Chapter 8.2 “Error messages” on page 83.

Viewing active error messages



Fig. 37: Two active notifications

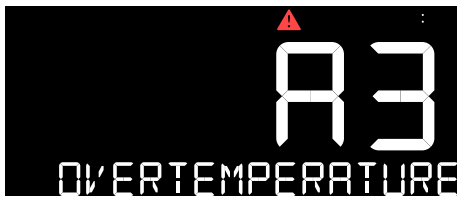

Fig. 39: Example: Active excess temperature alarm A3

1. Select the *NOTIFICATIONS* menu item and press the [Enter key] to access the error messages in the display.

► The number of active notifications is displayed.

Note: If there are no active messages, [EMPTY] is displayed.



Fig. 38: No active notifications

2. Press the [Enter key] when the number of active messages is displayed in order to then use the arrow keys to view the active messages.
3. Clear alarms and warnings if their cause has been eliminated with the [Enter key], if necessary.



Error messages with an error code starting with E.. cannot be cleared, see ↪ “Error” on page 83.

6.8 [CALIBRATION] – Calibrating the temperature probe

If, when checking the temperature in a steady state, you discover a constant temperature deviation of T_{INT} from the reference thermometer, this can be equalled out via the [CALIBRATION] menu item.

In the [CALIBRATION VALUE] menu item, the temperature sensor characteristic is adjusted in parallel by the input value (1-point comparison).

In the [CALIBRATION RESET] menu item, the factory calibration can be reset.



You can change the temperature value T_{INT} within the range of ± 3 K.

Carrying out a comparison



A calibrated reference thermometer with the desired level of accuracy is necessary. Otherwise, you should not change the calibration of your constant temperature equipment.



Fig. 40: Current offset



Fig. 41: Temperature value of the bath temperature probe



Fig. 42: Temperature value of the reference thermometer

- The reference thermometer must be immersed in the bath, in accordance with the requirements of the calibration certificate.
- To measure the temperature, wait until the system is in a steady state.

1. Select the *CALIBRATION* → *CALIBRATION VALUE* menu item.
 - ▶ The [CALIBRATION VALUE] menu item is displayed with the currently set offset.

2. Press the [Enter key].
 - ▶ The current temperature value of the bath temperature probe (T INT) flashes in the [CALIBRATION VALUE] menu item.

3. Use the arrow keys to set the temperature value according to the temperature value read from the reference thermometer, and confirm with the [Enter key].
 - ▶ The new calibration value is applied and the new offset is displayed.



Fig. 43: New offset

Restoring the factory calibration

If you wish to restore the calibration configured in the factory, carry out the reset as follows.

1. Select the *CALIBRATION* → *CALIBRATION RESET* menu item.
2. Select the [YES] option and press the [Enter key] to confirm.
 - ▶ This deletes the user's calibration and restores the calibration as it was configured in the factory.

6.9 [RESTORE FAC. SET.] – Restoring the factory settings

Restore factory setting

If you wish to restore the device's factory settings, carry out the reset as follows.

1. Select the *RESTORE FAC. SET.* menu item and press the [Enter key].
2. Select the [YES] option and press the [Enter key] to confirm.
 - ▶ The settings carried out by the user are reset to the factor settings.

Factory setting values

Table 23: Control system

Parameter	Description	Factory setting
T SET	Set temperature	20°C
T IH	Upper temperature limit	Specific to device
T IL	Lower temperature limit	Specific to device
Standby	---	STOPPED (standby on)
TIME ZONE	Time zone	GMT+00/ UTC+00 (London)

Table 24: Cooling system

Parameter	Description	Factory setting
COOL MODE	Cooling unit operating mode	AUTO (auto-matic)

Table 25: Network

Parameter	Description	Factory setting
WLAN	WLAN function	OFF (off)
PC CONTROL	Ethernet interface	OFF (off)
PORT	Port number	49152
INTERFACE TIMEOUT	Connection monitoring	15
Webserver	Web server function	OFF (off)
LAUDA.LIVE	Cloud function	OFF (off)
LAUDA.LIVE		OFF (off)
■ OP. PRM. READABLE	Op. param. readable	OFF (off)
■ OP. PRM. WRITABLE	Op. param writeable	OFF (off)

Parameter	Description	Factory setting
■ SVC. PRM. READABLE	Service prm. readable	OFF (off)
■ SVC. PRM. WRITABLE	Service prm. writeable	OFF (off)

7 Maintenance

7.1 Maintenance safety instructions



Prior to carrying out commissioning work, you must

- disconnect all interface cables from the device and
- deactivate the WLAN in the device menu.



DANGER!
Contact with live or moving parts

Electric shock, impacts, cutting, crushing

- The device must be disconnected from the mains power supply before any kind of maintenance is performed.
- Only skilled personnel are permitted to perform repairs.



DANGER!
Risk of moisture/cleaning agent penetrating into the device

Electric shock

- Use a slightly damp cloth to clean the device.



WARNING!
Damage to surfaces during cleaning

Burning, fire, device damage

- Do not damage the cooling circuit.
- Do not use aggressive cleaners to clean the pump and control unit.
- Do not use chlorine-based cleaners for the bath vessel and evaporator.
- Do not use sharp or pointed objects to clean the evaporator.



WARNING!
A functional failure of the excess temperature and low-level protection is not detected

Burns, scalding, fire

- Check the excess temperature and low-level protection every time the heat transfer liquid is changed, and according to the defined maintenance intervals at the latest.



CAUTION!
Contact with hot / cold device parts, accessories and heat transfer liquid

Scalding, hot or cold burns

- Allow device parts, accessories and heat transfer liquid to reach room temperature before touching.

7.2 Maintenance intervals

Interval	Maintenance work
Before switching on the device	Check the power supply cable for damage
As required, once a month at the latest	(Visually) inspect the external hoses, tubing clips and screw connections for leaks and damage.
after changing the heat transfer liquid, once a month at the latest	Check the excess temperature and low-level protection, see ↪ Chapter 7.5 “Check excess temperature and low-level protection device” on page 81.
As required, every three months at the latest	Clean the air-cooled condenser
quarterly (a shorter interval must be selected, depending on the water hardness and operating period)	Descale the cooling water circuit and the cooling coil
As required, once every six months at the latest	Check that the heat transfer liquid is suitable for use
As required, once a year at the latest	Check the external condition of the device for damage and stability
Annually	Check the cooling water quality (Limits, see ↪ Chapter 4.5 “Cooling water requirements” on page 39)
Every twenty years	Replacement of safety-related electrical and electromechanical components by LAUDA Service, This includes the circuit breaker and the excess temperature and low-level protection.

7.3 Cleaning the air-cooled condenser



WARNING!
Risk of mechanical damage to refrigerant circuit

Burns, fire

- Do not damage the cooling circuit.
- Use suitable materials/tools to clean the condenser (e.g. soft brush, vacuum cleaner or compressed air).
To do this, remove the detachable cover plate from the front of the device.

Removing the front panel

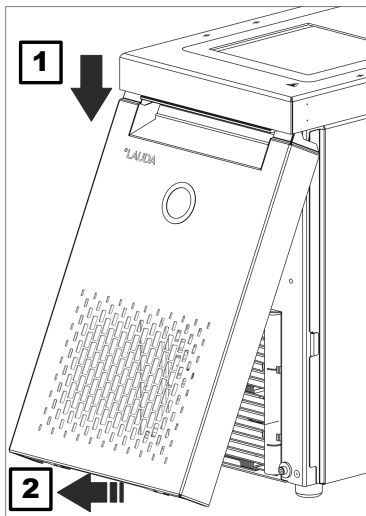

Fig. 44: Removing the front panel

1. Hold the front panel at the sides and slide it down (1).



The front panel is attached to the bottom of the chassis by two magnets.

2. Tilt the lower end of the front panel outward as shown in the image (2).
3. Slide the top of the front panel further down and pull the front panel away from the unit.

Installing the front panel

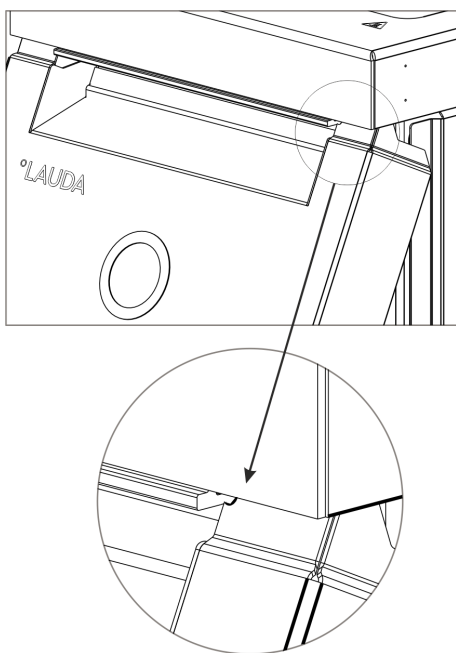

Fig. 45: Curves on the front panel

1. Hold the front panel at the sides, tilt the top edge toward the device and slide under the bath edge.
2. Push the front panel upward but make sure that the curves are still visible Fig. 45.
3. Push the lower end of the front panel toward the bottom edge of the chassis.
4. Slide the front panel vertically upward all the way under the bath edge.
 - ▶ The small tabs at the bottom of the front panel slide into the chassis.
5. Check that the front panel is installed correctly by attempting to pull the bottom end of the front panel outward. The front panel should sit firmly.
 - ▶ You have installed the front panel correctly.

7.4 Check the heat transfer liquid



WARNING!
Contact with hot/cold heat transfer liquid

Scalding, cold burns

- Bring the heat transfer liquid to room temperature for analysis.



NOTICE!
Wear, contamination, dilution of the heat transfer liquid

Device damage

- The serviceability of the heat transfer liquid must be checked if necessary (e.g. if the operating mode is changed) but at every prescribed maintenance interval at the latest.
Continued use of the heat transfer liquid is only permitted if the check indicates this.



Wear of the heat transfer liquid

- *Heat transfer liquid is subject to wear.*
- *The serviceability of the heat transfer liquid must be checked if necessary (e.g. if the operating mode is changed), at least every six months.*
- *Continued use of the heat transfer liquid is only permitted following successful testing.*

- Protective equipment:
- Safety glasses
 - Protective gloves
 - Protective work clothing

Where applicable, the following points should be considered when testing the heat transfer liquid:

Water content

1. For water/monoethylene mixtures and water/propylene mixtures:
The water content decreases during longer periods of operation at higher temperatures and the mixture becomes flammable.

Cloudiness

2. The water becomes opaque or cloudy due to micro-organisms, suspended matter and deposits.

Discoloration

3. The liquid turns yellow, green or brown due to algae growth and bacterial decomposition processes

Odor

4. The liquid emits a moldy musty odor due to bacteria and fungal growth.

Application

5. General deterioration in thermal performance.
Reduction in the achievable temperature stability.
Clogging of hoses.

7.5 Check excess temperature and low-level protection device



WARNING!
Contact with hot or cold heat transfer liquid

Scalding, cold burns

- Bring the heat transfer liquid to room temperature before draining.

The check is carried out with a drained bath and the heating switched on. After a short while, the device should trigger an excess temperature alarm as soon as the safety temperature limiter switches on, due to the temperature being too high at the heater.

1. Set the temperature set point to 10°C.
2. Switch off the device.
3. Drain the bath.
4. Switch the device back on.
5. Set the temperature set point to the maximum possible value.

After 45 seconds at the latest, an excess temperature is triggered. The device switches to fault mode and the excess temperature alarm A3 is displayed.



If, after 45 seconds, an excess temperature alarm is not triggered, shut down the device and contact LAUDA Service.

6. Set the temperature set point to 10°C.
7. Switch off the device.
8. Pull the mains plug out of the power socket.
9. Wait 30 minutes until the heater has cooled down.
10. Reset the triggered safety temperature limiter, see ↩ Step 3 on page 87.
 - ▶ You can now refill the device, put it back into operation and clear the alarm with the Enter key.

8 Faults

Troubleshooting/fault elimination and repair



DANGER!
Contact with live or moving parts

Electric shock

- Before starting any service or repair work, switch off the device and pull out the mains plug.
- Only skilled personnel are permitted to perform service and repair work.



DANGER!
Incorrect handling

Explosion, burns, fire

- Only certified specialists who are trained to handle flammable refrigerants are authorized to perform repair and disposal work.
- In order to avoid the risk of possible ignition due to incorrect maintenance or the installation of incorrect parts, only specialists certified by the manufacturer are authorized to carry out maintenance.
- Any components and parts must be replaced with identical parts.

8.1 Alarms, errors and warnings

Universa ECO devices emit alarms, warnings or error messages in the event of faults or other causes, such as incorrect configuration. The way the device behaves depends on the type of message and the user action required.

Alarms

Alarms affect safety. The device's components, such as the pump and heating, switch off. Alarms are indicated with the alarm symbol and two beeps. In addition the alarm code (A..) appears on the display with a text message.

Once the cause of the fault has been eliminated, alarms can be cleared in the [NOTIFICATIONS] menu item with the Enter key.

You can find a list of alarms in Table 26 "Alarms" on page 83.

Warnings

Warnings are not safety-related; the device continues to operate. Warnings are indicated by one short beep; a message does not appear on the display. You can view active warnings (W..) in the [NOTIFICATIONS] menu item. Once the cause of the fault has been eliminated, warnings can be cleared in the [NOTIFICATIONS] menu item with the Enter key.

You can find a list of alarms in Table 27 "Warnings" on page 84.

Error

In the event of an error, the components of the device, such as the pump and heating, switch off. Errors are indicated with the alarm symbol and a double beep. In addition the error code (E..) appears on the display with a text message.

You can clear error messages with the Enter key. If this happens, switch off the device at the mains switch. If the error occurs again after switching on the device, make a note of the error code and the corresponding description, and contact the LAUDA Service department. You will find the contact information here ↪ Chapter 1.17 “Contact LAUDA” on page 11.

You can find a list of alarms in ↪ Table 28 “Error” on page 85.

8.2 Error messages

Table 26: Alarms

Code	Message	Description	Possible remedy
A3	overtemperature	Safety temperature limiter on the heater has triggered due to excess temperature. This can also occur due to fill level being too low (low-level protection)	<ul style="list-style-type: none"> ■ Check the fill level in the bath. The heater must be completely covered with liquid. ■ Check the temperature in the bath. It should not exceed the specified maximum temperature. ■ Wait until the temperature in the bath or on the heater has cooled down to below the switch-off point, and reset the safety temperature limiter, see ↪ Chapter 8.2.1 “Excess temperature alarm A3” on page 86. ■ The safety temperature limiter could be defective. Contact LAUDA Service, ↪ Chapter 1.17 “Contact LAUDA” on page 11.
A22	connection lost	Disconnection at the network interface.	<ul style="list-style-type: none"> ■ The interface cable is not connected. Check the cable connection. ■ The interface cable is defective. Replace the cable. ■ The interface timeout has been exceeded. Send periodic commands to the thermostats or adjust the timeout value in the <i>NETWORK</i> → <i>REMOTE CONTROL</i> → <i>TIMEOUT</i> menu, see ↪ “Connection monitoring” on page 60

Table 27: Warnings

Code	Message	Description	Possible remedy
W3	til limit active	Lower temperature limit T _{IL} or tolerance threshold reached.	Check the setting and your application, see ↗ Chapter 5.4.2 “Setting the temperature limits” on page 45.
W4	tih limit active	Upper temperature limit T _{IH} or tolerance threshold reached.	Check the setting and your application, see ↗ Chapter 5.4.2 “Setting the temperature limits” on page 45.
W7	parameter invalid	Invalid device parameter	
W33	calibration	Incorrect temperature probe calibration	<ul style="list-style-type: none"> ■ Carry out a calibration and if there is a deviation from the reference thermometer, carry out an adjustment, see ↗ “Carrying out a comparison” on page 73. ■ If necessary, reset the factory calibration, see ↗ “Restoring the factory calibration” on page 74. ■ If the fault continues, contact LAUDA Service.
W34	stack Overflow	Memory overflow	Switch off the device at the main switch and switch it back on again after waiting for at least 60 seconds. If the fault continues, contact LAUDA Service.
W35	network config	Incorrect network configuration	Check the network configuration, see ↗ Chapter 6.5 “[NETWORK] – Network, web server and cloud” on page 55.
W37	mac missing	MAC address is missing	Contact LAUDA Service, ↗ Chapter 1.17 “Contact LAUDA” on page 11.
W38	lauda live	Communication problem with the cloud	
W39	serial number	Serial number missing	
W40	bath. check menu	Incorrect setting for bath unit	<ul style="list-style-type: none"> ■ Check whether the 'BATH TYPE' setting corresponds to the type information on the bath unit's type plate. ■ Coding switch on cold conductor plate not set correctly, contact LAUDA Service.
W46	fan	Fan speed too low	<ul style="list-style-type: none"> ■ In cooling mode, check the air flow in the condenser. ■ Clean the condenser. ■ If the fault continues, contact LAUDA Service.
W49	app	Communication problem with the app	Contact LAUDA Service, ↗ Chapter 1.17 “Contact LAUDA” on page 11.
W51	active con.		
W53	clocks	Inconsistent system clock	

Code	Message	Description	Possible remedy
W54	setpoint range	Set temperature outside TI L or TI H limit;	Selected set temperature is outside the possible range limited by the TI L and TI H temperature limits. Check the settings and your application. See from ↗ Chapter 5.4.1 “Sequence and limitation of inputs” on page 45.
W55	sw version web	Software version of web server and control system are incompatible. Can occur after an interrupted update procedure.	<ul style="list-style-type: none"> ■ Carry out software update again, see . ■ Printed circuit board defective Contact LAUDA Service, ↗ Chapter 1.17 “Contact LAUDA” on page 11.
W56	cert missing	Problem with device certificate. Possible impact on cloud and web server functionality	

Table 28: Error

Code	Message	Description	Possible remedy
E1	cpu	CPU error	Switch off the device at the main switch and switch it back on again after waiting for at least 60 seconds. If the fault continues, contact LAUDA Service, ↗ Chapter 1.17 “Contact LAUDA” on page 11.
E2	register	Register error	
E3	ram	RAM error	
E5	mcu clk	System clock	
E8	storage defect	memory defect	
E15	aggregate wrong	wrong cooling unit	<ul style="list-style-type: none"> ■ Check whether the [BATH TYPE] setting corresponds to the type information on the bath unit’s type plate. ■ The coding switch on the printed circuit board in the cold bath has not been set correctly. Contact LAUDA Service. ■ The voltage variant of the pump and control unit has been configured incorrectly or does not correspond to the cold bath. Contact LAUDA Service, ↗ Chapter 1.17 “Contact LAUDA” on page 11.
E16	flash	memory error	Switch off the device at the main switch and switch it back on again after waiting for at least 60 seconds. If the fault continues, contact LAUDA Service.
E17	fwu processing	Error occurred during software update	<ul style="list-style-type: none"> ■ Switch off the device at the main switch and switch it back on again after waiting for at least 60 seconds. ■ Observe the information in and repeat the update procedure. If the fault continues, contact LAUDA Service.
E19	int pt break	Break at the temperature probe T INT	Switch off the device at the main switch and switch it back on again after waiting for at least 60 seconds. If the fault continues, contact LAUDA Service.

Code	Message	Description	Possible remedy
E20	voltage wrong	5 V or 24 V voltage not OK	Switch off the device at the main switch and switch it back on again after waiting for at least 60 seconds. If the fault continues, contact LAUDA Service.
E21	int pt short	Short circuit at temperature probe T INT	Switch off the device at the main switch and switch it back on again after waiting for at least 60 seconds. If the fault continues, contact LAUDA Service.
E28	key defect	Operating key(s) defective or pressed when switching on	<ul style="list-style-type: none"> ■ You have pressed and held down keys while the device was switching on ■ Defective keys on the control panel. Switch off the device at the main switch and check the correct mechanical function of the keys by means of the pressure points. Switch off the device and switch it back on again after waiting for at least 60 seconds. If the fault continues, contact LAUDA Service.
E56	bath. check menu	Incorrect setting for bath unit	<ul style="list-style-type: none"> ■ Check whether the [BATH TYPE] setting corresponds to the type information on the bath unit's type plate. ■ The coding switch on the printed circuit board in the cold bath has not been set correctly. Contact LAUDA Service.
E69	pump overtemp.	Excess temperature at the pump motor	<ul style="list-style-type: none"> ■ The pump is clogged. Clean the pump housing. ■ The viscosity of the heat transfer liquid is too high. Use approved heat transfer liquid. ■ The ambient temperature is too high. Ensure sufficient aeration or set up air conditioning in the room. ■ The pump is defective. Switch off the device at the main switch, pull out the mains plug and eliminate the cause if necessary. Switch the device back on after a sufficient waiting time and check the circulation in the bath during operation. If the fault continues, contact LAUDA Service.

8.2.1 Excess temperature alarm A3

The excess temperature alarm is triggered by a safety temperature limiter (STL). The STL's sensor is attached at the device's heater. The STL has a permanently set switch-off point and is triggered in the temperature range between 118 and 125°C. After being triggered due to excess temperature, the STL's snap-action switch is manually reset.

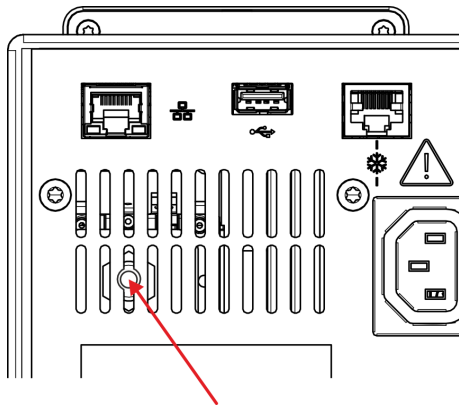

Fig. 46: Position of the button

1. Check the fill level in the bath and top up the heat transfer liquid, if necessary. The thermostat's heater must be completely covered with liquid.
2. Switch off the thermostat and pull out the mains plug from the socket.
3. To reset the excess temperature alarm, press the button (using a ballpoint pen, for example) on the STL behind the ventilation grid to unlock the snap-action switch of the restart lock.
4. Switch the thermostats back on.
5. Select the [NOTIFICATIONS] menu item and clear the excess temperature alarm A3 with the Enter key.

9 Decommissioning

9.1 Changing/draining heat transfer liquid

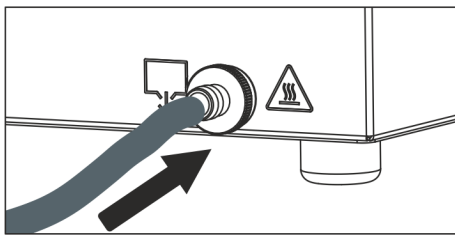

Fig. 47: Attaching hose



WARNING!
Contact with hot or cold heat transfer liquid

Scalding, cold burns

- Bring the heat transfer liquid to room temperature before draining.



WARNING!
Splashing heat transfer liquid

Eye damage

- Always wear suitable safety glasses when working on the device.



Observe the regulations for the disposal of used heat transfer liquid.

1. Allow the device and heat transfer liquid to cool or warm up to room temperature.
2. Turn off the device and pull out the mains plug.
3. Attach a hose to the drain nozzle.



On cooling thermostats:

The drain nozzle is located behind the removable front panel, see ↪ “Removing the front panel” on page 79.

4. Place the hose in a suitable container to collect the heat transfer liquid.



It may be necessary to drain the device several times if the filling volume is high.

5. Open the drain tap by turning it counterclockwise.



Drain the bath, external consuming unit, accessories and hoses completely.

6. If necessary, clean or flush out the device (with new heat transfer liquid, for example).



After changing to a different heat transfer liquid, you may have to set new values for the temperature limit, overtemperature switch-off point and/or the controller output limit.

10 Disposal

10.1 Disposing of the refrigerant



DANGER!
Uncontrolled leaking of refrigerant

Explosion, burns, fire

- Never dispose of a cooling circuit that is still pressurized.
- Only certified specialists who are trained in the handling of flammable refrigerants are permitted to perform disposal work.

Personnel: Certified specialist



The type and filling weight of the refrigerant are indicated on the type plate.

1. Always have any repair and disposal work carried out by a certified refrigeration technician.

10.2 Device disposal



The following applies for EU member states: The device must be disposed of according to Directive 2012/19/EU (WEEE Waste of Electrical and Electronic Equipment).

10.3 Disposing of packaging

The following applies for EU member states: Disposal of the packaging must proceed according to regulation 94/62/EC.

11 Technical data

11.1 General technical data

Table 29: Universa ECO display

Specification	Value	Unit
Display	VA-LCD segmented display with two-line display	---
Display size	3	inches
Display resolution	0.1	°C
Setting resolution	0.1	°C

Table 30: Device data

Specification	Value	Unit
Installation and use	Indoors	---
Use up to a maximum height above sea level of	2,000	m
Overvoltage category	II	---
Protection class for electrical equipment DIN EN 61140 (VDE 0140-1)	1	---
Class division according to DIN 12876	NFL (suitable for non-flammable liquids)	---
Heating thermostat temperature stability ¹	±0.05	K
Cooling thermostat temperature stability ¹	±0.05	K
Air humidity	Maximum relative humidity 80% at temperatures up to 31 °C, linearly decreasing until 50% relative humidity at 40 °C	%
Degree of pollution according to EN 60664-1 / VDE 0110-1	Pollution degree 2 only <u>non-conductive</u> contamination, whereby temporary conductivity caused by condensation is occasionally expected	---
Ambient temperature with bath temperature up to maximum 100°C	5–40	°C
Storage temperature	5–40	°C
Transport temperature	-20 – 43	°C
IP code according to EN 60529	IP 21	---
Mains voltage tolerance range (heating ther- mostats) Cooling thermostat, see ↪ Table 31 “Mains voltage tolerance ranges on cooling thermo- stats” on page 91	with 200–240 V power supply: up to ±10% of the nominal voltage with 100 – 125 V power supply: up to +5% / -10% of the nominal voltage with 100 V power supply up to ±10% of the nominal voltage	---
With WLAN module installed:		

Specification	Value	Unit
- RF output (theoretical maximum value)	19.96	dBm EIRP
- Frequency range	2.400–2.4835	GHz

¹ - Temperature stability determined according to standard DIN 12876

Table 31: Mains voltage tolerance ranges on cooling thermostats

Cooling thermostat device type	Voltage [V]	Tolerance range	Frequency [Hz]
U 830 E	100	±10%	50/60
U 830 E	110–125	+5% / -10%	60
U 830 E	220–240	±10%	50/60
U 1225 E	100	±10%	50/60
U 1225 E	110–125	+5% / -10%	60
U 1225 E	220–240	±10%	50/60
U 1625 E	100	±10%	50/60
U 1625 E	110–125	+5% / -10%	60
U 1625 E	220–240	±10%	50/60

11.2 Stainless steel bath thermostats

Table 32: Universa ECO immersion thermostat

	Unit	ECO
Working temperature range	°C	35 – 100
Extended working temperature range ¹	°C	20 – 100
Operating temperature range ²	°C	-30 – 100
Device dimensions (W x D)	mm	195 x 231
Device height (H)	mm	307
Bath depth	mm	At least 140
Noise level ³	dB(A)	38
Weight	kg	3.5
Clearance		
- Front	mm	200
- Back	mm	200
- Right	mm	200
- Left	mm	200

¹ - Cooling with cooling coil

² - With external cooling

³ - Noise level determined according to standard EN 11201 for operating position in front of the device at 1 meter distance

Table 33: Universa ECO bath thermostats with stainless steel bath

	Unit	U 8 E	U 12 E	U 16 E
Working temperature range	°C	35 – 100	35 – 100	35 – 100
Extended working temperature range ¹	°C	20 – 100	20 – 100	20 – 100
Operating temperature range ²	°C	-30 – 100	-30 – 100	-30 – 100
Device dimensions (W x D)	mm	230 x 400	280 x 450	280 x 550
Device height (H)	mm	450	450	450
Bath opening (W x D)	mm	150 x 150	200 x 200	200 x 300
Bath depth (H)	mm	200	200	200
Usable depth	mm	180	180	180
Height top of bath	mm	280	280	280
Filling volume				
- Minimum	L	6.6	10.8	12.7
- Maximum	L	8.8	14.3	17.1

	Unit	U 8 E	U 12 E	U 16 E
Noise level ³	dB(A)	38	38	38
Weight	kg	13	15.5	16.5
Clearance				
- Front	mm	200	200	200
- Back	mm	200	200	200
- Right	mm	200	200	200
- Left	mm	200	200	200

¹ - Cooling with cooling coil

² - With external cooling

³ - Noise level determined according to standard EN 11201 for operating position in front of the device at 1 meter distance

Table 34: Universa ECO bath thermostats with transparent bath

	Unit	U 6 TE	U 15 TE	U 20 TE
Working temperature range	°C	35 – 100	35 – 100	35 – 100
Extended working temperature range ¹	°C	20 – 100	20 – 100	20 – 100
Operating temperature range ²	°C	-20 – 100	-20 – 100	-20 – 100
Device dimensions (W x D)	mm x mm	189 x 435	432 x 189	363 x 510
Device height (H)	mm	379	529	381
Bath opening (W x D)	mm x mm	130 x 270	263 x 130	300 x 343
Bath depth (H)	mm	160	310	160
Usable depth	mm	140	290	140
Height top of bath	mm	206	356	206
Filling volume				
- Minimum	L	5.2	13.2	13.3
- Maximum	L	8.0	15.0	20.0
Noise level ³	dB(A)	38	38	38
Weight	kg	5.9	7.1	8.8
Clearance				
- Front	mm	200	200	200
- Back	mm	200	200	200
- Right	mm	200	200	200
- Left	mm	200	200	200

- ¹ - Cooling with cooling coil
- ² - With external cooling
- ³ - Noise level determined according to standard EN 11201 for operating position in front of the device at 1 meter distance

11.3 Cold bath thermostats

Table 35: Universa ECO cold bath thermostats

	Unit	U 830 E	U 1225 E	U 1625 E
ACC area ¹	°C	-30 – 100	-25 – 100	-25 – 100
Device dimensions (W x D)	mm	260 x 480	310 x 510	310 x 610
Device height (H)	mm	630	630	630
Bath opening (W x D)	mm	150 x 150	200 x 200	200 x 300
Bath depth (H)	mm	200	200	200
Usable depth	mm	180	180	180
Height top of bath	mm	460	460	460
Filling volume				
- Minimum	L	6.4	9.9	12.8
- Maximum	L	8.5	13.4	17.1
Noise level ²	dB(A)	45	45	45
Weight	kg	28	31	33.8
Clearance				
- Front	mm	200	200	200
- Back	mm	200	200	200
- Right	mm	200	200	200
- Left	mm	200	200	200

- ¹ - ACC area (Active Cooling Control) according to DIN 12876 is the working temperature range during operation with an active cooling unit.
- ² - Noise level determined according to standard EN 11201 for operating position in front of the device at 1 meter distance

11.4 Hydraulic data

Table 36: Universa ECO

Specification		ECO	U 8 E, U 12 E, U 16 E
		U 6 TE, U 15 TE, U 20 TE	U 830 E, U 1225 E, U 1625 E
Pump type	---	Pressure pump	Pressure pump
Pump levels	Quantity	1	1
Pump data 50/60 Hz			

Specification		ECO	U 8 E, U 12 E, U 16 E
		U 6 TE, U 15 TE, U 20 TE	U 830 E, U 1225 E, U 1625 E
- Maximum discharge pressure	bar	0.2	0.2
- Maximum flow rate	l/min	15	15
Drain connection outer diameter	mm	---	Ø12

11.5 Current consumption and heating output

Table 37: Universa ECO immersion thermostat

Power supply	Current consumption in A	Maximum heating output in kW for lower / upper mains voltage
200–240 V; 50/60 Hz	10	1.6/2.2
100 – 125 V; 50/60 Hz	12	0.9/1.4
100 V; 50/60 Hz	11	1.0/1.0

Table 38: Universa ECO bath thermostat with stainless steel bath

Power supply	Current consumption in A	Maximum heating output in kW for Lower/upper mains voltage		
		U 8 E	U 12 E	U 16 E
200–240 V; 50/60 Hz	10	1.6/2.2	1.6/2.2	1.6/2.2
100 – 125 V; 50/60 Hz	12	0.9/1.4	0.9/1.4	0.9/1.4
100 V; 50/60 Hz	11	1.0/1.0	1.0/1.0	1.0/1.0

Table 39: Universa ECO bath thermostat with transparent bath

Power supply	Current consumption in A	Maximum heating output in kW for Lower/upper mains voltage		
		U 6 TE	U 15 TE	U 20 TE
200–240 V; 50/60 Hz	10	1.6/2.2	1.6/2.2	1.6/2.2
100 – 125 V; 50/60 Hz	12	0.9/1.4	0.9/1.4	0.9/1.4
100 V; 50/60 Hz	11	1.0/1.0	1.0/1.0	1.0/1.0

Table 40: Universa ECO cold bath thermostat

Power supply	Current consumption in A	Maximum heating output in kW for Lower/upper mains voltage		
		U 830 E	U 1225 E	U 1625 E
220–240 V; 50/60 Hz	10	1.6/2.2	1.6/2.2	1.6/2.2
110 – 127 V; 60 Hz	12	0.9/1.4	0.9/1.4	0.9/1.4
100 V; 50/60 Hz	11	1.0/1.0	1.0/1.0	1.0/1.0

11.6 Cooling capacity



The cooling output is measured when the heat transfer liquid reaches a certain temperature. The ambient temperature for the measurement is 20°C and ethanol is used as a heat transfer liquid.

Universa ECO cooling thermostats

Table 41: Cooling unit 50/60 Hz

	Unit	U 830 E	U 1225 E	U 1625 E
Cooling output at 20°C	W	300	300	300
10°C	W	275	260	260
0°C	W	230	220	220
-10°C	W	175	145	140
-20°C	W	100	65	55
-25°C	W	---	30	20
-30°C	W	10	---	---

11.7 Refrigerant and filling charge

Cold bath thermostats

Table 42: Universa ECO single-stage cooling unit

	Unit	U 830 E	U 1225 E	U 1625 E
Natural refrigerant	---	R-600a	R-600a	R-600a
Maximum filling weight	kg	0.03	0.03	0.03
GWP _(100a) *	---	3	3	3



Global Warming Potential (GWP), CO₂ comparison = 1.0
* Time frame 100 years - according to IPCC IV

11.8 Heating curves

Heating curves measured with water as a heat transfer liquid and a closed bath cover.

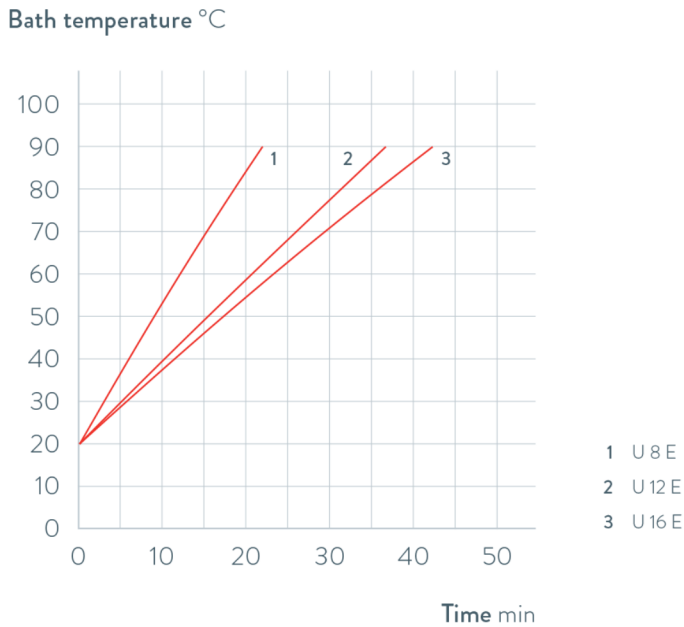

Fig. 48: Heating curves for Universa ECO heating thermostats

11.9 Cooling curves

Cooling curves measured with ethanol as a heat transfer liquid and a closed bath cover.

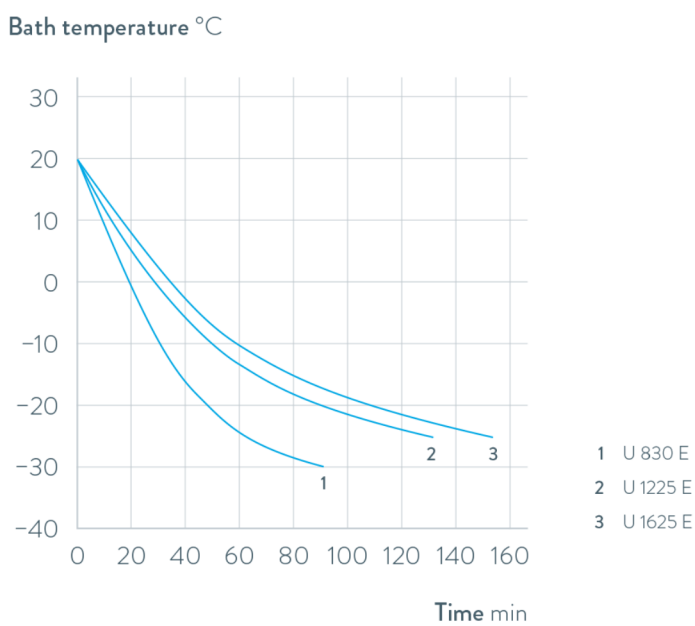

Fig. 49: Cooling curves for Universa ECO cooling thermostats

11.10 Pump characteristics

Pump characteristics measured with water

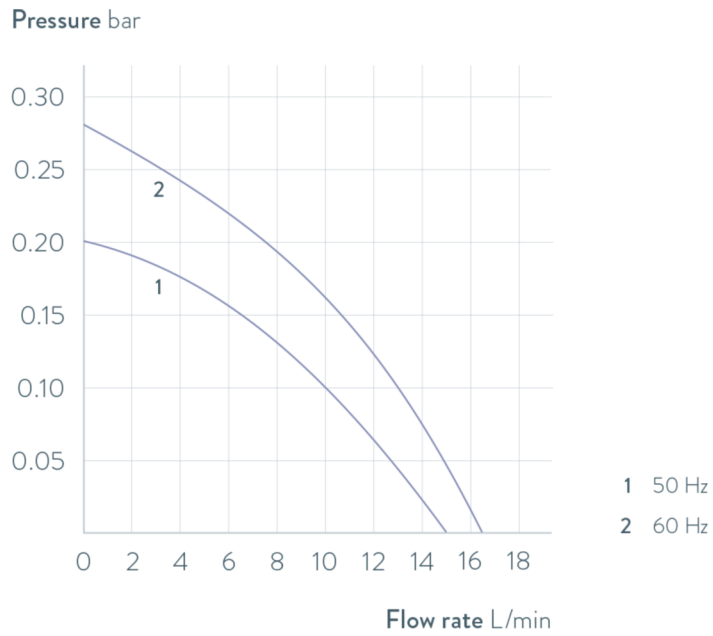

Fig. 50: Universa ECO pump characteristics

12 Accessories

The following optional accessories are available for Universa ECO devices.

Table 43: Racks and inset basket for bath vessel

Accessories for Universa ECO	Characteristic	Suitable for	Part number
Test tube racks in Z shape	with 36 openings, Diameter 17 mm	U 8, U 830	A001652
	with 49 openings, Diameter 13 mm	U 8, U 830	A001653
	with 64 openings, Diameter 17 mm	U 12, U 1225	A001654
	with 100 openings, Diameter 13 mm	U 12, U 1225	A001655
Hanging rack	for test tubes, External D = 16 mm	U 8, U 830	A001664
	for test tubes, External D = 30 mm	U 8, U 830	A001665
Inset basket	140x140x195 mm	U 8, U 830	LCZ 0658
Inset basket	180x190x195 mm	U12	LCZ 0694

Bath cover

Table 44: Bath cover for Universa ECO heating and cooling thermostats, stainless steel baths and cold baths

Designation	Device type	Bath opening (W x D) in mm x mm	Quantity	Part number
Bath cover	U 8, U 8 E, U 830, U 830 E	150 x 150	1	A001661
	U 12, U 12 E, U 1225, U 1225 E	200 x 200	1	A001662
	U 16, U 16 E, U 1625, U 1625 E	200 x 300	1	A001663

Table 45: Bath cover for Universa ECO heating thermostats with transparent bath

Designation	Device type	Bath opening (W x D) in mm x mm	Quantity	Part number
Bath cover	U 6 TE	130 x 270	1	A001769
	U 15 TE	270 x 130	1	A001770
	U 20 TE	300 x 350	1	A001771

Bath cover for ducts or openings

Table 46: Bath cover for Universa thermostats

Designation	Suitable for	Bath opening (W x D) in mm x mm	Quantity	Part number
Bath cover with ducts	U 8 E, U 830 E	150 x 150	1	A001658
Bath cover with ducts	U 12 E, U 1225 E	200 x 200	1	A001659
Bath cover with ring inserts: 4 openings	U 8 E, U 830 E	150 x 150	1	A001744
Bath cover with ring inserts: 5 openings	U 12 E, U 1225 E	200 x 200	1	A001745

Table 47: Hydraulic components

Designation	Suitable for	Characteristic	Part number
Pump connector set	Universa ECO	With 11-mm stainless steel hose nozzles	A001738
Cooling coil set	Universa ECO	With 13-mm stainless steel hose nozzles	A001741

① I = internal screw thread (female)

② E = exterior thread (male)

Table 48: Fastening components, mounts

Designation	Suitable for	Characteristic	Part number
Standard rail Stainless steel 25 mm x 10 mm	U 8	Length: 394 mm	A001666
	U 12	Length: 444 mm	A001667
	U 830	Length: 440 mm	A001668
	U 1225	Length: 484 mm	A001669
	U 16	Length: 534 mm	A001670
	U 1625	Length: 604 mm	A001671
Standard rail clamp for pipes	A001666 to A001671	Mounting hole: M10	A001720
Cover bracket	A001666 to A001671	compatible with standard rails	A001721
Base with castors	U 8, U 12, U 16, U 830, U 1225, U 1625	adjustable	A001746

13 Declaration of Conformity



EC DECLARATION OF CONFORMITY

Manufacturer: LAUDA DR. R. WOBSEER GMBH & CO. KG
Laudaplatz 1, 97922 Lauda-Königshofen, Germany

We hereby declare under our sole responsibility that the machines described below

Product line Universa **Serial number** from S250000001

Types: U 4 E (U 4 + ECO), U 8 E (U 8 + ECO), U 12 E (U 12 + ECO), U 16 E (U 16 + ECO),
U 6 TE (U 6T + ECO), U 15 TE (U 15T + ECO), U 20 TE (U 20T + ECO),
U 20 E (U 20 + ECO), U 40 E (U 40 + ECO)
ECO

comply with all relevant provisions of the EC Directives listed below due to their design and type of construction in the version brought on the market by us:

Radio Equipment Directive	2014/53/EU (only for devices with radio certification markings on the rating plate of the pump and control unit)
Machinery Regulation	(EU) 2023/1230 (valid from 20.01. 2027)
Machinery Directive	2006/42/EU (valid until 19.01.2027)
EMC Directive	2014/30/EU
RoHS Directive	2011/65/EU in conjunction with (EU) 2015/863

The protection objectives of the Machinery Regulation (or Directive) with regard to electrical safety are complied with in accordance with Annex III (or Annex I) paragraph 1.5.1 with conformity to the Low Voltage Directive 2014/35/EU.

The machine or the associated product is subject to the conformity assessment procedure the basis of an internal production control (Module A according to (EU) 2023/1230).

Applied standards (date of publication in the Official Journal of the European Union is given in brackets if applicable):

- EN ISO 12100:2010 (exp.08.04.2011)
- EN 61010-1:2010/A1:2019/AC:2019-04 (exp. 30.11.2020)
- EN IEC 61326-1: 2021
- EN IEC 61010-2-010:2020 (exp. 22.06.2021)

*FAHRENHEIT. *CELSIUS. *LAUDA.

Q5WA-QA13-068-EN-01

LAUDA

Only for devices with radio certification markings on the rating plate of the pump and control unit:

- EN IEC 62311:2020
- ETSI EN 300 328 V2.2.2 (2019-07) (exp. 06.02.2020)
- ETSI EN 301 489-1 V2.2.3 (2019-11)
- ETSI EN 301 489-17 V3.2.4 (2020-09)

Authorized representative for the compilation of technical documentation:
Dr. Jürgen Dirscherl, Head of Research & Development

Signed in the name of: LAUDA DR. R. WOBSEY GMBH & CO. KG

Lauda-Königshofen, 10.12.2025



Dr. Marc Stricker,
Managing Director (COO)

Only for devices with radio certification markings on the rating plate of the pump and control unit:

- EN IEC 62311:2020
- ETSI EN 300 328 V2.2.2 (2019-07) (exp. 06.02.2020)
- ETSI EN 301 489-1 V2.2.3 (2019-11)
- ETSI EN 301 489-17 V3.2.4 (2020-09)

Authorized representative for the compilation of technical documentation:

Dr. Jürgen Dirscherl, Head of Research & Development

Signed in the name of: LAUDA DR. R. WOBSEER GMBH & CO. KG

Lauda-Königshofen, 10.12.2025



Dr. Marc Stricker,
Managing Director (COO)

14 Product Returns and Clearance Declaration

Product Returns

Would you like to return a LAUDA product you have purchased to LAUDA? For the return of goods, e.g. for repair or due to a complaint, you will need the approval of LAUDA in the form of a *Return Material Authorization (RMA)* or *processing number*. You can obtain the RMA number from our customer service department at +49 (0) 9343 503 350 or by email service@lauda.de.

Return address

LAUDA DR. R. WOBSEY GMBH & CO. KG
Laudaplatz 1
97922 Lauda-Königshofen
Deutschland/Germany

Clearly label your shipment with the RMA number. Please also enclose this fully completed declaration.

RMA number	Product serial number
Customer/operator	Contact name
Contact email	Contact telephone
Zip code	Place
Street & house number	
Additional explanations	

Clearance Declaration

The customer/operator hereby confirms that the product returned under the above-mentioned RMA number has been carefully emptied and cleaned, that any connections have been sealed to the farthest possible extent, and that there are no explosive, flammable, environmentally hazardous, biohazardous, toxic, radioactive or other hazardous substances in or on the product.

Place, date	Name in block letters	Signature

15 Index

A

Accessories	
In series	15
Alarm	82
A22	60
Codes	83
Description	83
Application	
connection	37
disconnection	37
Arrow button (illustration)	23

B

Bath cover (illustration)	19, 21
Bath drain tap (illustration)	19, 21
Bath draining nozzle (illustration)	19, 21
Bath unit	55

C

Calibration	
Ex works	73
Calibration (actual temperature)	
Determine	73
Certificate	
CA	66
Download	66
Check	
Excess temperature protection	81
Heat transfer liquid	79
Cloud	68
Code	
Alarms	83
Error	85
Warning	84
Cold bath control cable (illustration)	21
Compressor	24
Condenser	
cleaning	78
Connection monitoring	60

Connection socket	
Cold bath control cable	17
Cold bath power supply	17
Consumer	
connection	37
Contact	11
Control cable (illustration)	21
Control panel buttons (illustration)	23
Cookies	67
Cooling	
Operating mode	52
Without reheating	52
Cooling coil	
Description	24
cooling thermostat	
Structure	21
Cooling unit	
Setting	52
Cooling water	
Requirements	39
Copyright	10
D	
Defining limit values (temperature)	46
Defining temperature limit values	46
Device	
Disposal (packaging)	89
Draining	88
Filling	47
Device type	55
DIN EN 378-1	8
Display	
Actual bath temperature	43
Home window (structure)	43
Position	16
Display buttons	
Operation	23
Disposal	
Packaging	89
Refrigerant	89

Disposing of the refrigerant	89	I	
Draining		ID	66
Device	88	Input button (illustration)	23
E		Intended use	6
Error	83	Interface	
Codes	85	Description	23
Description	83	Ethernet	59
E56	55	Overview	23
Error messages	72	Timeout	60
Establishing a mains connection	41	Interface functions	
Establishing a power supply	41	Read commands	61
Ethernet interface	59	Write commands	64
Evaporator	24	IP address	66
Excess temperature protection		L	
Check	81	LAUDA.LIVE	
Definition	11	Access	68
Expansion	24	Cloud	68
F		M	
Factory calibration	73	Mains switch	
Factory setting		Operation	23
Cooling	52	Position	17
Factory settings	75	Maintenance	
Fault	82	Intervals	78
Feet (illustration)	19, 21	Maximum temperature	81
Filling	47	Messages	72
Flushing	88	Module slot	
Front panel		Position	17
removing	78	O	
Front panel (illustration)	21	Offset (actual temperature)	
H		Calibrate	73
Heat transfer liquid		Operating buttons	
Check	79	Position	16
Flushing	88	P	
Heater		Packaging	
Position	16	Disposal	89
Home window		Personal protective equipment (overview)	13
Structure	43	Personnel qualification (overview)	12
Hydraulic circuit		Power supply cable (illustration)	17
Description	24	Protective equipment (personal, overview)	13

Pt100		Temperature set point	
Position	16	Setting	47
Pump		Time zone	70
Connection (illustration)	19, 21	Timer	53
Description	24	Type plate	
Pump and control unit		Description	25
Installation	29	Device (illustration)	20, 21
Structure	16	Pump and control unit (illustration)	17
Pump outlet		U	
Internal bath circulation (illustration)	16	Unpacking	15
R		USB interface	23
Read commands	61	Position	17
Recessed grip (illustration)	21	V	
Refrigerant		Ventilation grid (illustration)	21
Flammable	8	Viscosity	9
Refrigerating machine		W	
Function	24	Warning	82
Removing		Codes	84
the heat transfer liquid	88	Description	83
S		W40	55
Safety temperature limiter (STL)	17	Warranty	10
Serial numbers	25, 66, 72	WLAN	57
Service	11	SAR limits	59
Set temperature	47	Write commands	64
Setting the date	70		
Setting the time	70		
Shutdown timer	53		
Software update	69		
Carrying out an update	71		
USB interface	17		
Software version	69		
Software versions	72		
Specific density	9		
Symbol			
Cloud	68		
T			
T SET	47		
Technical data	90		
Temperature probe			
Position	16		

Manufacturer:

LAUDA DR. R. WOBSE GMBH & CO. KG ° Laudaplatz 1 ° 97922 Lauda-Königshofen

Telephone: +49 (0)9343 503-0

E-mail: info@lauda.de ° Internet: <https://www.lauda.de>